

# Multilin™ B95Plus

## Bus Protection System



### Reduce the time and cost of field wiring for bus protection

The Multilin™ B95Plus Bus Protection System is the ideal solution for one of the biggest challenges for large bus protection: the time and cost involved in the design, installation and commissioning of the field wiring between measurements from the switchyard and the bus relay in the control room. The HardFiber Brick, the environmentally hardened distributed bay unit of the B95Plus, directly reduces the time and costs involved in field wiring in both the short term and the long term.

Save time and money in the short term with flexible mounting options for the bay unit. The compact size and rugged design of the HardFiber Brick bay unit allows installation anywhere: outdoors in the switchyard, in equipment cabinets or in the control room. All data signals are converted to digital signals per the IEC 61850 standard and communicated over a single fiber optic cable, making the best location for installation next to the primary signal source, virtually eliminating all field wiring.

To save money in the long term, use the Brick bay unit as an IEC 61850 process bus merging unit. This becomes the complete I/O interface (including currents, voltages, equipment status and equipment control) for all protective relays and all zones of protection. Relay installation for any future zone of protection literally becomes plug-and-play: mount the relay on a panel, plug the relay into the fiber from the Brick bay unit and commission.

### Key Benefits

- Reduce field wiring costs by replacing multiple copper wires and terminations with a fiber optic cable
- Save installation costs by mounting the bay unit in harsh environments without requiring specialized enclosures
- Increase savings by connecting other relays to the same process bus bay unit
- Protect six three-phase differential zones with one central device

### Applications

- Reconfigurable multi-section bus bar with up to 24 feeders
- Retrofit and greenfield installations for power generation, transmission and distribution systems
- Reconfigurable bus bars for single bus, breaker-and-a-half and double bus with and without bus couplers
- Air-insulated and GIS stations

### Saves Field Wiring

- Terminate field wiring directly at bay unit located at the primary equipment
- Install connectorized fiber optic cable as only wiring across the switchyard
- Transfer work of designing, installing and commissioning field wiring for new installations to primary equipment suppliers

### Use as Distributed I/O

- The bay unit can be a distributed I/O interface for any protective relay
- Environmentally hardened, compact design allows installation in a substation without additional cost or equipment
- Measurements and commands transmitted via IEC 61850 message formats
- Interface to protective relays that support appropriate sampled value message formats per IEC 61850

### Meets Protection Needs

- Meets requirements for speed and reliability of bus protection for all configurations and voltage levels
- 6 zones of 3-phase protection and 24 feeders for breaker-and-a-half, double bus and segmented bus zones
- CT saturation detector capable of detecting CT saturation even with only 2 msec of saturation free current for enhanced fault stability
- Rconfigurable dynamic bus replica



## The Challenge in Bus Protection

### The Cost of Field Wiring

The challenge in bus protection for large bus architectures is the time to design, install and commission all of the associated field wiring. Every source in a bus protection zone requires extensive field wiring for the relay to acquire the current measurements and equipment status, and to issue control commands. Every signal used by bus protection requires a pair of copper wires. Every one of these wires between the primary equipment and the relay, and the terminations of these wires, must be designed, installed and commissioned for the specific project. Every one of these wires will be wired in series or parallel to protective relays associated with the zones of protection for the source, so this effort will be duplicated. This process is exceedingly labor-intensive, with most of the labor requirements being on-site manual labor. The end result is a very intensive and error-prone process that adds significant time and cost to every project and makes long term maintenance costly, and changes difficult to implement. This effort is very much the same if the project is installing a new bus protection system, or simply adding an additional source to an existing system.

### We Solve the Field Wiring Challenge with the B95<sup>Plus</sup>

The Multilin B95<sup>Plus</sup> Bus Protection System changes the focus of bus protection to that of application by replacing most of the field wiring with distributed I/O and fiber optic cables. The protection system consists of a distributed process interface (data acquisition and tripping) architecture using HardFiber Bricks as bay units, with centralized processing performed by the B95<sup>Plus</sup>. All copper field wiring is between primary equipment in the switchyard and Bricks, which ideally should be located at the primary equipment in the switchyard. Fiber optic cables connect Bricks to the B95<sup>Plus</sup>. For all applications, the installation is then identical: the physical interface consists of Bricks connected to a fiber optic cable. A single B95<sup>Plus</sup> is mounted in a relay cabinet, with the process cards in the unit patched to the fiber optic cables coming from the Bricks.

## HardFiber System

*The HardFiber System can easily be incrementally scaled to include new equipment as stations evolve. Duplicated Bricks in the switchyard provide a drastic improvement in reliability and security over today's technology.*

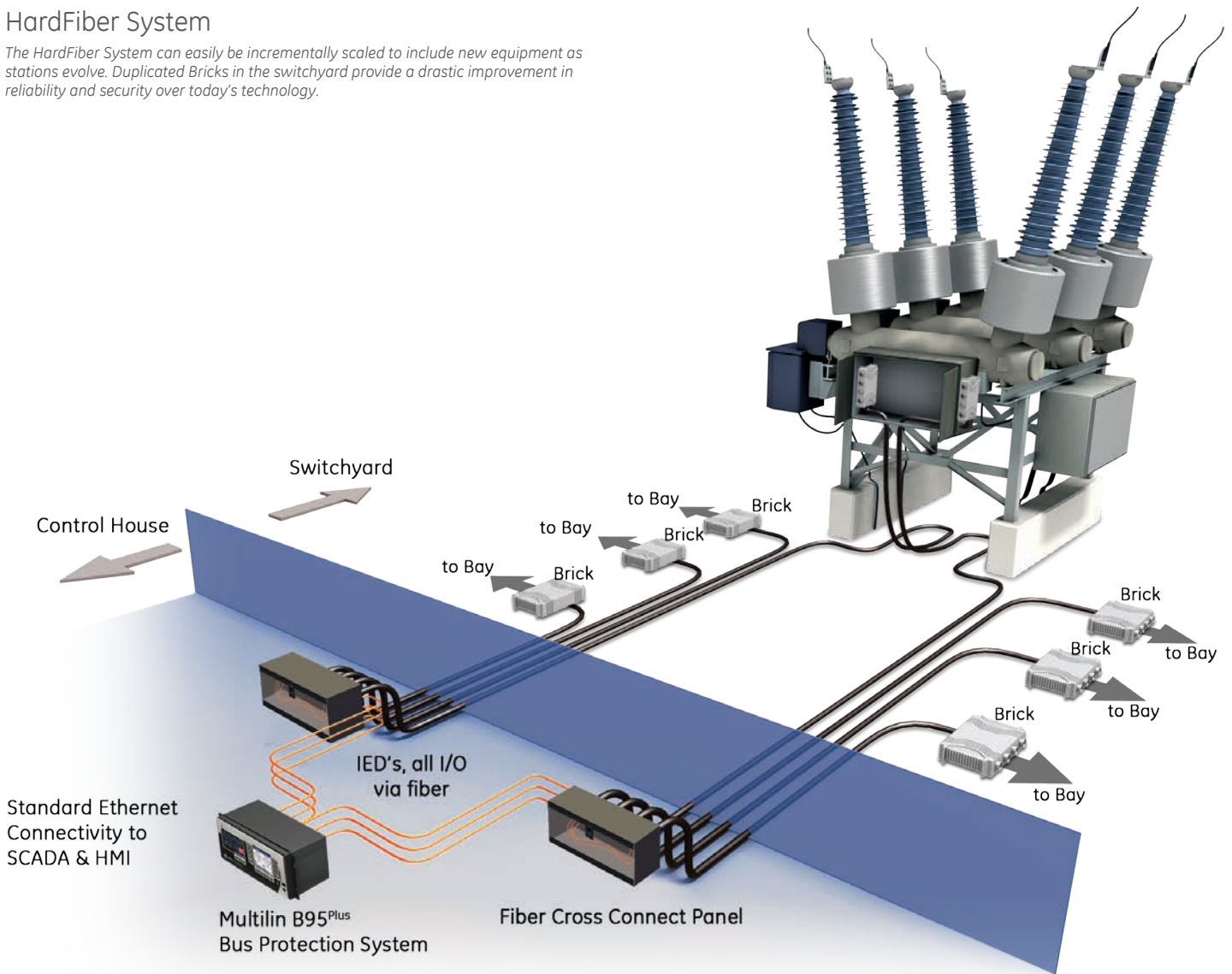

## B95<sup>Plus</sup> System Overview

### B95<sup>Plus</sup> Unit

The B95<sup>Plus</sup> unit is the heart of the system. This unit performs all processing functionality, including protection functions, metering, monitoring, FlexLogic and SCADA communications.



- Simplifies use through a Graphical User Interface (GUI) that includes configurable single line diagrams for bus sources, local control and status indication of breakers and disconnects, 20 programmable pushbuttons, and a configurable digital alarm annunciator
- Connects up to 8 Bricks for each process card while, supporting up to 12 bus sources per card
- Supports 2 process cards per unit, for a total of 16 Bricks and 24 bus sources
- Provides identical connections and installation for all bus configurations

### HardFiber Brick as Bay Unit

- Measurement and control for primary apparatus, including AC measurements (4 currents and 4 voltages, or 8 currents) and contact I/O (18 digital inputs and 7 digital outputs including a latching relay)
- Simple device with no field configuration or configuration settings
- Environmentally hardened for outdoor mounting in switchyards
- Connectorized cables for simple, tools-free field installation and removal
- IEC 61850 message formats for communications, including sampled value messaging for currents and voltages



### B95<sup>Plus</sup> as Part of Process Bus

The B95<sup>Plus</sup> system uses HardFiber Bricks as bay units. The Brick is a process bus interface unit that combines a process bus merging unit (to sample currents and voltages) with contact I/O (for equipment status and control). Once a Brick is installed in a B95<sup>Plus</sup> system, the Brick can interface with any other device that supports sampled value messages as per the IEC 61850 standard. Rather than duplicate field wiring from the bus source for a feeder zone of protection, simply patch any member of the Universal Relay family to the fiber optic cable from the Brick.

### Protection

The B95<sup>Plus</sup> system provides robust and reliable protection for all bus protection applications. Highlights of the protection functions related to bus protection include:

- Multi-zone differential protection with both restrained (dual-slope percent or biased) and unrestrained (unbiased or instantaneous) functions incorporated. Differential protection is fast (typical response time: 1 power system cycle) and secure. Security is achieved by using a fast and reliable CT saturation detection algorithm and a phase comparison operating principle. Security is further enhanced by support for redundant process interface units (Bricks). Supports both three-phase tripping and individual phase tripping.
- Dynamic bus replica functionality and multi-zone protection (up to 6 zones) is supported allowing application of the B95<sup>Plus</sup> to multi-section reconfigurable buses. A zone expansion/contraction to an open breaker feature is included. Isolator position monitoring for up to 48 isolators.
- Check-zone functionality configured by programming one of the differential zones to enclose the entire bus.
- Additional bus protection functions including end fault protection, breaker fail and overcurrent protection for each bus source, CT trouble monitoring for each bus zone.

## Functional Block Diagram

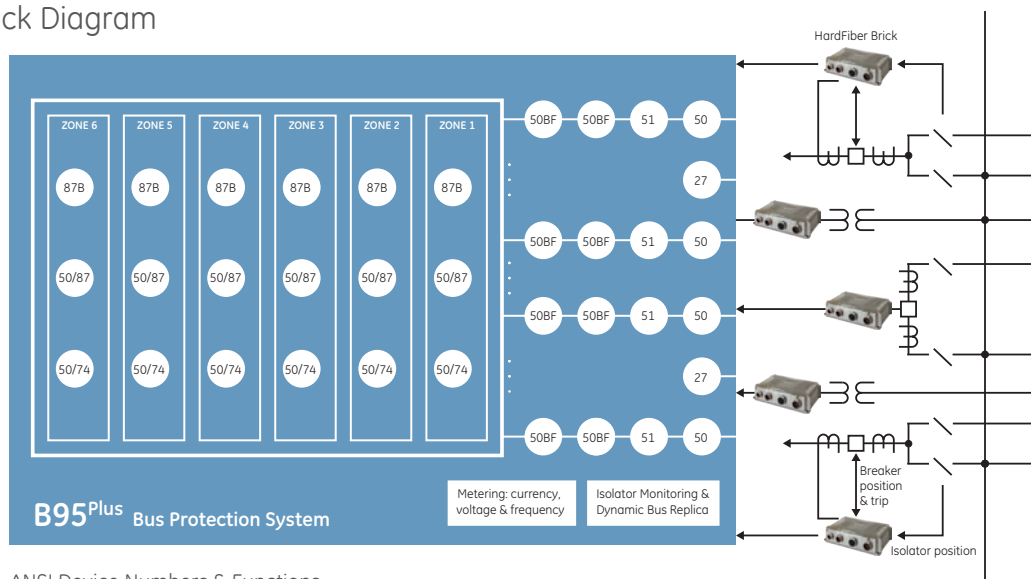

### ANSI Device Numbers & Functions

Device Number	Function	Device Number	Function
87B	Percent bus differential	50/87	Unrestrained bus differential
27	Undervoltage	50EF	End fault protection
50	Instantaneous overcurrent	51	Time overcurrent
50/74	CT trouble	50BF	Breaker failure

## Applying the B95<sup>Plus</sup>



### Reducing the Cost of Field Wiring

The distributed design of the B95<sup>Plus</sup> system separates field wiring from the control room. Bricks are environmentally hardened I/O devices, with no sophisticated processing and no configuration necessary, designed and intended to be installed in the switchyard close to the source of all measurements. Field wiring simply starts at the primary equipment, and ends at a Brick installed at the primary equipment. The number of wiring terminations is greatly reduced, and one fiber optic cable installed across the switchyard replaces multiple sets of copper cables. For new installations,

the equipment supplier can mount the Brick and install and terminate all field wiring to the Brick during their manufacturing process, transferring the work of field wiring completely away from the utility. Functionally this makes field wiring for the B95<sup>Plus</sup> part of the primary equipment of the switchyard, and allows all field wiring to be installed during the substation construction process.

### Brick with Primary Equipment

Reducing the equipment to control wiring to one fiber optic cable per Brick reduces wiring costs. There are fewer cables to install, requiring less time and effort. With fewer cables, less space in cable trench is required, saving costs by reducing the size of the cable trench. The fiber optic cables are designed to be direct buried, and can quickly be installed between primary equipment and cable trench. The cables are designed to be used with standard pulling equipment.

### Simple Cable Installation

Brick cables are connectorized cables for tools free installation and removal, to simply become an off-the-shelf component of the protection and control system. The connectors for the Brick cables are industry-standard parts that meet the MIL-DTL-38999 specification for cabling connectors. Each Brick has 3 copper cables (1 for AC measurements, 1 for inputs, and 1 for outputs) and 1 fiber optic cable. These cables are available for purchase from GE, or may be provided by any qualified cable supplier.

The end result is that field wiring is separated from the protection and control device, resulting in substantial savings in wiring costs by installing field wiring with the primary equipment.

### Flexible Mounting Options to Simplify Installation

Bricks are designed to be mounted outdoors in the switchyard directly on primary equipment or equipment cabinets. Mounting at the primary equipment is the most cost-effective method when new equipment is being installed in the substation, replacing field wiring terminations with Bricks and connectorized cables, while simultaneously needing a smaller cable trench. In many cases, however, the B95<sup>Plus</sup> will be used during a substation expansion project or refurbishment project. In these projects, much of the existing field wiring, already installed to the control house, may be used. The compact design of the Brick permits a wide range of mounting locations for where it is most cost effective to acquire measurement and status signals.

Bricks are compact enough to install inside existing equipment cabinets in the switchyard to keep field wiring and terminations in one common enclosure. Bricks may also be installed in the control house mounted on relay panels, directly connected to field wiring to acquire measurements and equipment status signals installed during the installation of the original primary equipment..

## Additional Mounting Options for the Brick

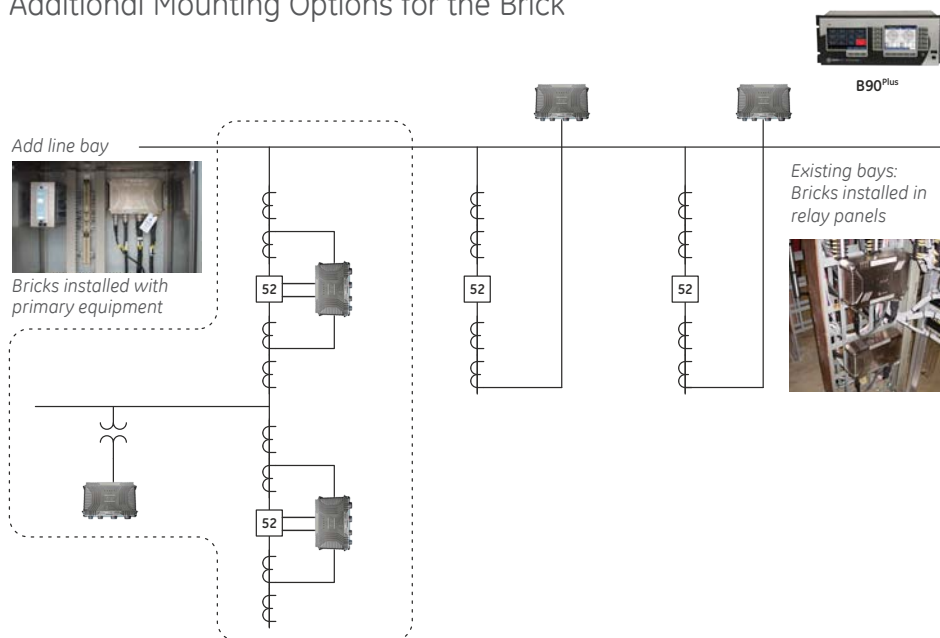

Brick as primary equipment



Simple fiber optic cable installation

## Standardize on the B95<sup>Plus</sup> for Any Bus Configuration

The B95<sup>Plus</sup> can be applied on a multitude of bus configurations due to the distributed architecture, and includes support for up to 6 zones of bus differential protection and support for up to 24 bus sources. The physical connection and wiring architecture for the B95<sup>Plus</sup> system will be identical for any bus configuration: Bricks installed to acquire measurements and equipment status, with the B95<sup>Plus</sup> unit connected to Bricks via fiber optic cables. The relay panel design will be identical for all applications, for all bus configurations. The only difference from application to application is the number and location of Bricks, and the programming of the B95<sup>Plus</sup> unit.

Some typical bus configurations that can be protected by the B95<sup>Plus</sup>:

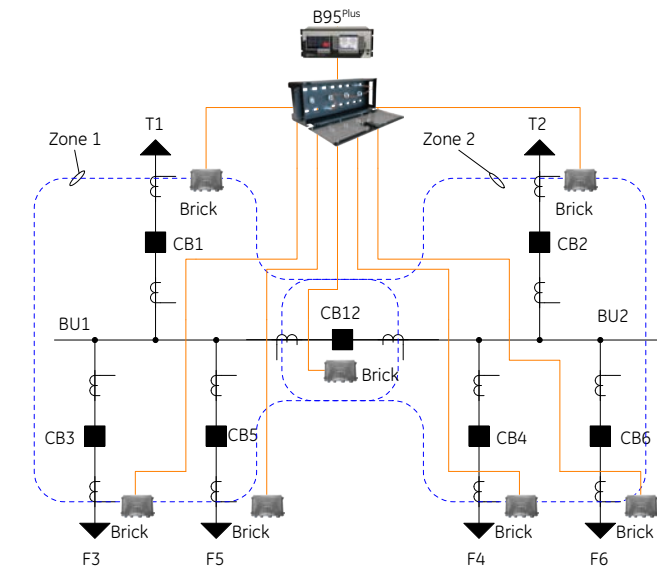

Two single buses with a bus coupler

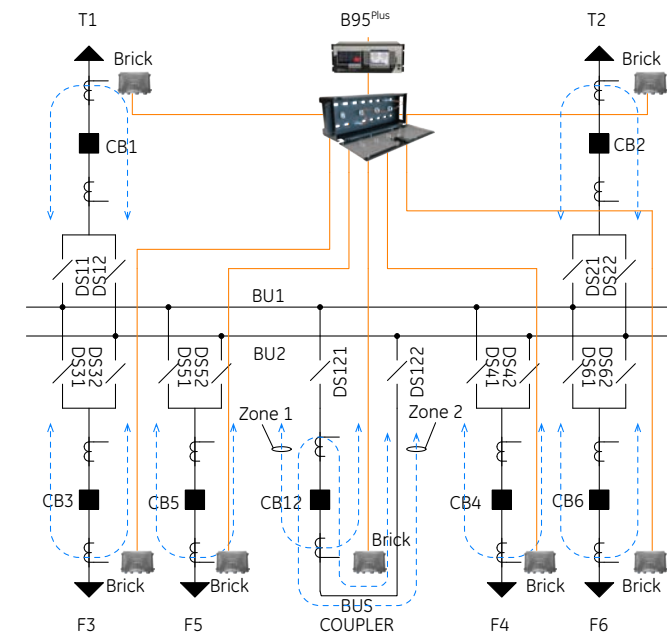

Double bus with a bus coupler

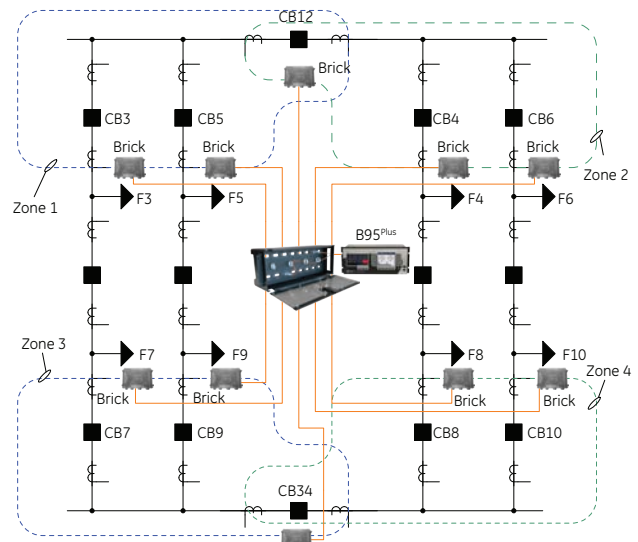

Breaker-and-a-half arrangement

## Quickly Expand Protection through Process Bus

The B95<sup>Plus</sup> Bus Protection System is intended to operate as a standalone, distributed bus protection system. The bay units for this system are Bricks, part of the HardFiber IEC 61850 process bus solution. Once the Bricks for the B95<sup>Plus</sup> are installed process bus data is available for use for any other zone of protection. The Bricks, then, are a distributed I/O interface for all protection functions and zones, not just the B95<sup>Plus</sup>. With the B95<sup>Plus</sup> in place, installing line protection or feeder protection is a simple process: mount the relays in a panel, and patch to the fiber optic cable from the appropriate Bricks. The only requirement is the relays must implement the appropriate IEC 61850 datasets to interface successfully with the Bricks. All members of the Universal Relay family have the ability to interface with Bricks.

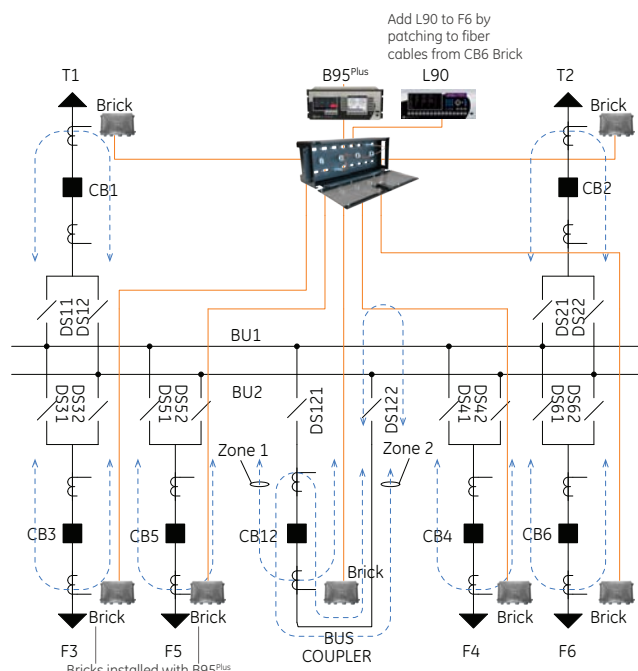

Expand protection through process bus

## Simple, Risk-Free Operation

The B95<sup>Plus</sup> system is designed to provide dependable and secure protection during normal bus maintenance operations, without requiring re-configuring of the bus protection, or enabling or disabling bus protection zones. The zone expansion/contraction feature dynamically changes the bus zone when a circuit breaker is opened to provide reliable protection and risk-free operations. The bus protection zone automatically reconfigures to one protection zone when a circuit breaker is connected to 2 buses during a bus transfer operation, once again providing risk-free operations. The B95<sup>Plus</sup> also supports the use of check zones by configuring one zone to protect the entire bus to account for unusual operating events such as a failure of isolator position monitoring.

### Breaker maintenance

End fault protection directly provides dependable and secure protection during breaker maintenance operations. End fault protection dynamically adjusts the bus protection zone based on the position of circuit breakers and their associated isolators. Once enabled during configuration, no user or operator input is required, as end fault protection adjusts the bus protection zone by monitoring the position of the isolators and the circuit breaker. No bus protection zone must be enabled or disabled, and no check zone is required to ensure dependable and secure protection.

### Switching operations

The B95<sup>Plus</sup> also provides dependable and secure protection when rolling a circuit breaker from one bus section to a different bus section. When a second isolator is closed, paralleling the two bus sections together, the B95<sup>Plus</sup> dynamically expands one of the bus protection zones to cover the entire paralleled bus. Once the first isolator is opened, and the buses are no longer paralleled, the B95<sup>Plus</sup> returns to two independent bus protection zones. Dependable and secure protection is maintained without requiring user or operator action, without the need to enable or disable bus protection zones, and without the need for a check zone.

PARAMETER (GROUP 1)	Z1	Z2	Z3	Z4	Z5	Z6
<b>General Settings</b>						
Function	Enabled	Enabled	Disabled	Disabled	Disabled	Disabled
Block	OFF	OFF	OFF	OFF	OFF	OFF
Auxiliary Zone Trip	OFF	OFF	OFF	OFF	OFF	OFF
Check-Zone	No	No	No	No	No	No
Events	Enabled	Enabled	Enabled	Enabled	Enabled	Enabled
<b>Characteristics Settings</b>						
<b>Supervision Settings</b>						
Zone Supervision 1/obj	ON	ON	ON	ON	ON	ON
Zone Supervision 1	ON	ON	ON	ON	ON	ON
Zone Supervision 2	OFF	OFF	OFF	OFF	OFF	OFF
Superv 1/td Delay	0.00 cycles	0.00 cycles	0.00 cycles	0.00 cycles	0.00 cycles	0.00 cycles

Bus zone configuration

PARAMETER (GROUP 1)	S1	S2	S3	S4	S5	S6	S7	S8	S9	S10	S11	S12
<b>General Settings</b>												
Function	Enabled	Enabled	Enabled	Enabled	Enabled	Enabled	Enabled	Enabled	Enabled	Enabled	Enabled	Enabled
Block	OFF	OFF	OFF	OFF	OFF	OFF	OFF	OFF	OFF	OFF	OFF	OFF
Auxiliary Zone Trip	OFF	OFF	OFF	OFF	OFF	OFF	OFF	OFF	OFF	OFF	OFF	OFF
Check-Zone	No	No	No	No	No	No	No	No	No	No	No	No
Events	Enabled	Enabled	Enabled	Enabled	Enabled	Enabled	Enabled	Enabled	Enabled	Enabled	Enabled	Enabled
<b>Characteristics Settings</b>												
<b>Supervision Settings</b>												
Zone Supervision 1/obj	ON	ON	ON	ON	ON	ON	ON	ON	ON	ON	ON	ON
Zone Supervision 1	ON	ON	ON	ON	ON	ON	ON	ON	ON	ON	ON	ON
Zone Supervision 2	OFF	OFF	OFF	OFF	OFF	OFF	OFF	OFF	OFF	OFF	OFF	OFF
Superv 1/td Delay	0.00 cycles	0.00 cycles	0.00 cycles	0.00 cycles	0.00 cycles	0.00 cycles	0.00 cycles	0.00 cycles	0.00 cycles	0.00 cycles	0.00 cycles	0.00 cycles

Bus source configuration

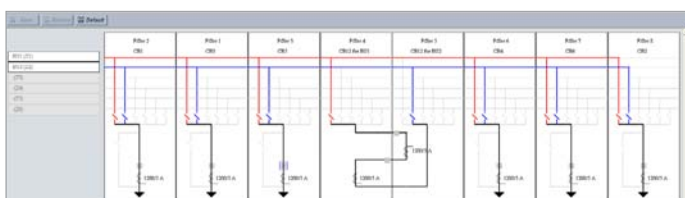

Intuitive configuration of bus replica

## Simple Configuration Reduces Operating and Maintenance Costs

The B95<sup>Plus</sup> system carries the time and cost savings on field wiring through to provide time and cost savings on system configuration. EnerVista™ B95<sup>Plus</sup> Setup software provides an intuitive method for configuring the 6 bus protection zones, the 24 bus sources, and the dynamic bus replica used for protection. Bus zones and bus sources are each configured on a single page with navigation to view all the settings. The software includes a search tool to find specific bus sources and settings.

The bus replica configuration uses an easy to understand electrical diagram in a graphical user interface to set up the system and the B95<sup>Plus</sup> relay. Each bus source is represented by a graphical object that simply snaps together with the objects for other sources on the electrical diagram. The entire bus replica is contained on one page for simple navigation and configuration. This results in simple management of the bus sources, the different protection zones, and the protection parameters.

### No configuration of the bay unit

The simple configuration of the B95<sup>Plus</sup> system also carries over to the bay units. The HardFiber Brick simply provides measurement, contact I/O, and communications, with no sophisticated processing. Therefore, there is no field configuration necessary for the Brick. The only configuration required is in the B95<sup>Plus</sup> central unit, to define the connections to specific Bricks.

## B95<sup>Plus</sup> Features

### Use the B95<sup>Plus</sup> as a Centralized DFR

The B95<sup>Plus</sup> has the capability to function as a basic centralized Digital Fault Recorder (DFR) at no additional cost. The unit includes specific transient recorder settings and digital triggers to initiate recording. The B95<sup>Plus</sup> can capture up to 50 individual oscillography records at sampling rates of up to 128 samples per cycle. Oscillographic data will include AC waveform channels from every enabled bus source and every enabled protection zone differential and restraint current. The oscillographic data can also include up to 384 digital channels. In addition, the B95<sup>Plus</sup> provides an event recorder that records the last 8,192 events time tagged at a 1 microsecond accuracy.

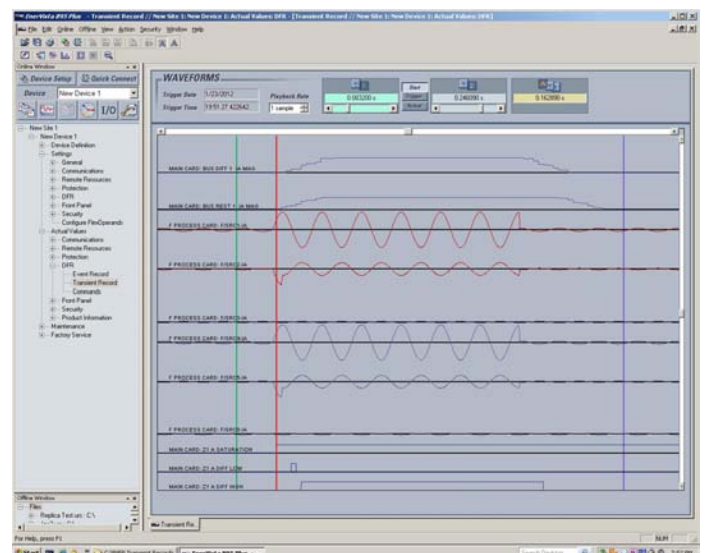

Transient recording data from the B95<sup>Plus</sup>

## FlexLogic™ Automation Logic

FlexLogic™ is the powerful user programmable logic engine that provides the ability to create customized protection and control schemes thereby minimizing the need, and the associated costs, of auxiliary components and wiring. FlexLogic can be used to implement basic control applications such as device interlocking and automatic switching routines, and advanced applications such as bus reclosing schemes. The B95<sup>Plus</sup> includes 512 line of FlexLogic with a deterministic execution rate of 1 msec irrespective of the number of lines of logic, plus an additional 512 lines of FlexLogic for each individual process card installed.

## Cyber Security and Process Bus

The B95<sup>Plus</sup>, despite the use of the HardFiber Brick as a bay unit, does not introduce any special cyber security requirements under NERC CIP rules. The communications architecture is a point-to-point architecture, with no remote access to the communications between the B95<sup>Plus</sup> central unit and the Bricks. The messaging between the B95<sup>Plus</sup> and the Bricks is completely, physically sealed from the outside world, so there are no special concerns with regards to cyber security.

## Cables

The HardFiber Brick uses connectorized cables to interface with primary equipment and with system measurements, and to interface to the B95<sup>Plus</sup> itself. The cables at the Brick end uses an IP67 certified industry standard connector designed for rugged environments. These connectors screw onto the Brick for a simple, tools-free connection. Three of the cables are copper cables used to acquire AC measurements, acquire equipment status, and provide equipment control. The fourth cable provides the fiber interface to the B95<sup>Plus</sup> central unit as well as DC power to the Brick. These cables therefore can become standard parts, manufactured in advance of installation by any cable manufacturer. These cables are also directly available from GE Digital Energy.

## Communications

The B95<sup>Plus</sup> provides for secure remote data and engineering access, making it easy and flexible to use and integrate into new and existing infrastructures. Fiber optic Ethernet provides high-bandwidth communications allowing for low-latency controls and high-speed file transfers of relay fault and event record information. The availability of three independently configurable Ethernet option provides the means of creating fault tolerant communication architectures in

an easy, cost-effective manner. The B95<sup>Plus</sup> supports the most popular industry standard protocols enabling easy, direct integration into SCADA systems.

- IEC 61850
- DNP3.0
- IEC60870-5-104
- Modbus RTU, Modbus TCP/IP

## Interoperability with Embedded IEC 61850

The B95<sup>Plus</sup> with integrated IEC 61850 can be used to lower costs associated with protection, control and automation.

- Replace expensive copper wiring between devices with direct transfer of data using GOOSE messaging
- Configure systems based on IEC 61850 and also monitor and troubleshoot them in real-time with EnerVista™ Viewpoint Engineer
- Integrate GE Multilin IEDs and generic IEC 61850-compliant devices seamlessly in EnerVista™ Viewpoint Monitoring

## EnerVista™ Software

The EnerVista™ Suite is an industry-leading set of software programs that simplifies every aspect of using the B95<sup>Plus</sup> relay. The EnerVistaT suite provides all the tools to monitor the status of your the protected asset, maintain the relay, and integrate information measured by the B95<sup>Plus</sup> into DCS or SCADA monitoring systems. Convenient COMTRADE and Sequence of Events viewers are an integral part of the B95<sup>Plus</sup> Setup software included with every relay, to carry out postmortem event analysis to ensure proper protection system operation.

## EnerVista Launchpad

EnerVista Launchpad is a powerful software package that provides users with all of the setup and support tools needed for configuring and maintaining GE Multilin products. The setup software within Launchpad allows configuring devices in real-time by communicating using serial, Ethernet, or modem connections, or offline by creating setting files to be sent to devices at a later time. Included in Launchpad is a document archiving and management system that ensures critical documentation is up-to-date and available when needed. Documents made available include:

- Manuals
- Application Notes
- Guideform Specifications
- Brochures
- Wiring Diagrams
- FAQ's
- Service Bulletins

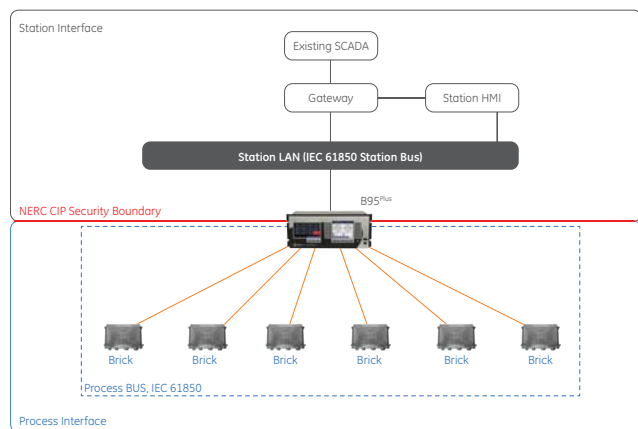

Cyber security and process bus



B95<sup>Plus</sup> cables

## User Interface

The B95<sup>plus</sup> provides local HMI capability through two color LCD display panels. One serves as a digital annunciator and the other HMI is for display and control functions.

### Annunciator

The B95<sup>plus</sup> provides an embedded, configurable color LCD annunciator on the front panel of the device eliminating the need for separate annunciators in the relay panel.



12 to 48 user configurable alarms per page eliminates the need for separate annunciator.

- The status of any contact or remote input or internally generated Flexlogic command can be assigned to the annunciator.
- The annunciator can display 12/24/48 targets per page to a maximum of 8 pages.
- A separate self-test message page on annunciator panel shows error messages and troubleshooting advice.
- Display analog values to create a customized metering screen

### HMI

- Comprehensive data visualization.
- Single line diagrams for bay monitoring and control.
- User pushbuttons can be assigned to several functions through multiple menu levels.
- Local/Remote control
- Pre-programmed comprehensive displays for:
  - Metering
  - Bay Control
  - Fault Reports
  - Sequence of Event Reports
  - Transient Records Summaries
  - Disturbance Record Summaries
  - Real Time Phasor Displays of Voltage, Current and Sequence Components

DFR - SEQUENCE OF EVENTS		
Delta: 0 days 00:00:00-013891		Event 427 & 426
Event#	Date/time	Cause
431	Mar 05 2007 12:23:23.637727	Cont Ip 8 On
430	Mar 05 2007 12:23:23.637727	Cont Ip 7 On
429	Mar 05 2007 12:23:23.637727	Cont Ip 6 On
428	Mar 05 2007 12:23:23.637727	Cont Ip 5 On
427	Mar 05 2007 12:23:20.735543	Dist Z1 OP
426	Mar 05 2007 12:23:20.721634	Dist Z1 PKP
425	Mar 05 2007 12:23:20.721634	Dist Z2 PKP
424	Mar 05 2007 12:23:20.721634	Dist Z3 PKP
423	Mar 05 2007 12:23:20.721634	OSC Trigger

[Up ▲] [Down ▼] [Retrieve] [Lock Cursor] [More ▶]

Sequence of event records with the ability to view time difference between two events for troubleshooting and analysis.

## Typical Wiring Diagram

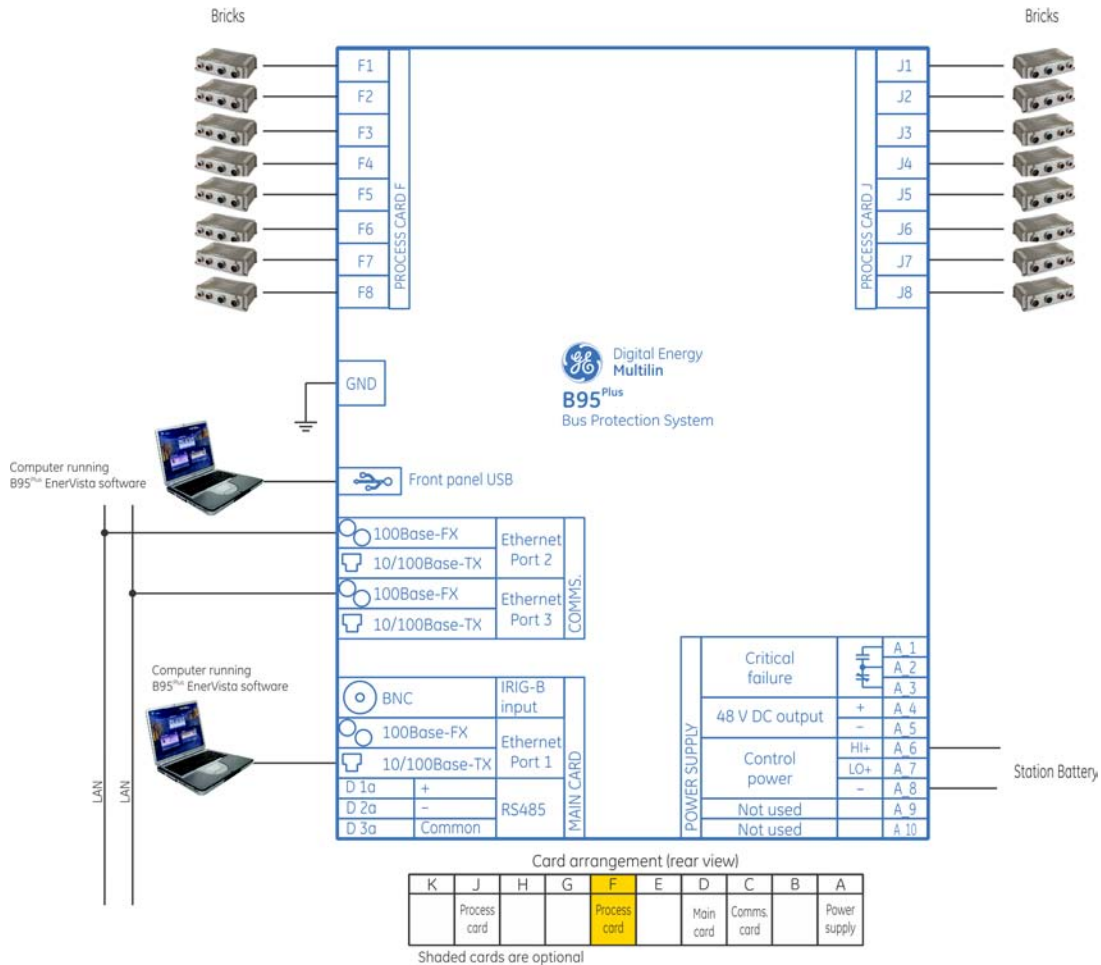



# Specifications

## BUS DIFFERENTIAL PROTECTION

Number of differential zones	Six 3-phase zones
Max number of currents:	Total dynamic number of bus source to zone connections closed at any one moment in time up to 120
CT ratio compensation range	32:1
Operating time	< 1 power system cycle - typical bus fault

## BUS REPLICA

Features	Dynamic bus source current assignment to each zone, dynamic zone trip assignment to each bus source, dynamic blocking of zones on CT bypassed, 1 user programmable auxiliary zone trip inputs, 3 user programmable bus source trip inputs, dynamic zone expansion/reduction
----------	-----------------------------------------------------------------------------------------------------------------------------------------------------------------------------------------------------------------------------------------------------------------------------

## BUS SOURCES

Number of bus sources	12 per process card included in the order code.
Current inputs	3-phase currents
CT rated primary	1 to 65000 A
CT rated secondary	1 A or 5 A
Nominal frequency	50 or 60 Hz
CT Trouble Monitoring	1 element per bus source
Breaker failure protection	1 element per bus source
Instantaneous Phase Overcurrent	1 element per bus source
Inverse Time Phase Overcurrent	1 element per bus source

## VOLTAGE SOURCES

Number of voltage sources	2 per process card included in the order code
Voltage inputs	3-phase voltages, wye or delta
VT ratio	1.00 V to 24000.00
VT rated secondary	25.0 V to 240.0 V
Nominal frequency	50 or 60 Hz

## ISOLATORS

Number of isolators	48 per process card included in the order code
Isolator status inputs	Form "a" and form "b" contact inputs, each optionally dual redundant
Configurable failsafe modes	Open, closed, last valid state
Monitoring	Alarm on inconsistent inputs persisting longer than a user set time

## TRANSIENT RECORDER

Storage capacity	Five records with all channels recorded, at 128 samples per cycle, spanning 1 second with no retriggers
Number of records	1, 2, 5, 10, 20, 30, 40, or 50 records
Sampling rate	16, 32, 64 or 128 samples per power cycle
AC waveform channels	All enabled bus sources and voltages sources
Analog channels	Magnitudes and angles of all ac waveforms recorded plus all enabled zone differential and zone restraint phase current magnitudes and angles
Digital channels	128 user configurable channels on the main card and 128 user configurable channels on each process card
Configurable digital data	Any FlexLogic™ operand
Storage modes	Automatic overwrite, protected
Triggering modes	Time window from rising edge of trigger, continuous recording up to 4 additional basic record lengths as long as retrigger is active
Pre-trigger window	0 to 100% of the basic record length
Data storage	non-volatile memory

## EVENT RECORDER

Storage capacity	8,192 events plus 8,192 events on each process card
Time tag:	to 1 μs
Triggers	all FlexLogic™ operand activations

## PROCESS I/O

Number of process bus ports	8 per process card
Port type	100Base-BX-D, in SFP package with LC 50/125μm multi-mode connector
Transceiver diagnostics	per SFF-8472
Brick synch frame jitter	±1μs

## POWER SUPPLY

Nominal DC voltage	125 to 250 V
Minimum DC voltage	80 V
Maximum DC voltage	300 V
Nominal AC voltage	100 to 240 V at 50/60 Hz
Minimum AC voltage	80 V at 48 to 62 Hz
Maximum AC voltage	275 V at 48 to 62 Hz
Voltage withstand	2 × highest nominal voltage for 10 ms
Voltage loss ride-through	200 ms duration at nominal input voltage
Power consumption	150 VA maximum

## PROCESS CARD OPTICAL

Number of transceivers	8
Transceiver type:	Transmit 1550 nm, receive 1310 nm, 100Mb/s, bi-directional single-fiber 50/125μm multi-mode module (levels comply with IEEE 802.3 standard 100Base-BX-D)
Optical transmit power	-14 to -8 dBm
Maximum optical input power	-8dBm
Optical receiver sensitivity	-30dBm
Termination	LC fiber connector
Laser class	Class 1. This product is eye-safe under all operating conditions.

## REMOTE RESOURCE SPECIFICATIONS

Number of field units	8 per process card
Number of field contact inputs	1 for each brick contact input
Number of field contact outputs	1 for each brick contact output
Number of field latching outputs	1 for each brick latching output
Number of shared inputs	16 per process card
Number of shared outputs	16 per process card

## APPROVALS AND CERTIFICATION

Compliance	CE, UL, ISO
------------	-------------

COMPLIANCE	APPLICABLE COUNCIL DIRECTIVE	ACCORDING TO
CE	Low voltage directive	EN 60255-27 (normative sections)
	EMC directive	EN 60255-26 / EN 50263 EN 61000-6-5 (Area G)
UL	cULus	UL 508
		UL 1053
		C22.2 No 14
ISO	Quality management system	ISO 9001

## Ordering Configurations

B95P	-	*	*	-	*	*	**	*	*	*	-	*	Slot											Description
Interface		H	E										A	B	C	E	F	G	H	J	K			
Front Panel		H																					Annunciator + HMI (Standard)	
Language			E																				English (Standard)	
<b>Features</b>																								
Protection				S	B																		Dynamic Bus Differential Protection (Standard) Dynamic Bus Differential Protection with Breaker Failure	
<b>Automation</b>						X																	None	
Communications							01																ModBus TCP/IP (Standard) + IEC 61850 + IEC61850 + DNP 3.0 TCP/IP	
							02																+ IEC61850 + IEC 60870-5-104	
Metering								S															AC Input Phasors + Differential & Restraint Phasors (Standard)	
DFR									S														Transient Recorder + Sequence of Events (Standard)	
Equipment Manager											X												None	
<b>Hardware</b>																								
Harsh Environment Coating											X	C											None (Standard) Harsh Environmental Conformal Coating	
Power Supply													H										High (88-275Vac/80-300Vdc) (Standard)	
Peer-to-Peer Communications Module														X									None (Standard)	
Communication Module															A								Dual ST Fiber & Copper (Standard)	
URPlus Process Card																	X	X	X	X	X	X	None	
(If only one process card, it must be in slot J)																		P			P		Each Supports 8 Bricks & 12 Bus/Voltage Sources	

Brick	-	4	-	H	I	-	*	*	*	*	Description
CT/VT Inputs							C	C	5	5	Standard Brick with Eight 5 A CT Inputs
							C	V	5	0	Standard Brick with Four 5 A CT Inputs and Four VT Inputs
							C	C	1	1	Standard Brick with Eight 1 A CT Inputs
							C	V	1	0	Standard Brick with Four 1 A CT Inputs and Four VT Inputs

### Order Code Example

(1) B95P	-	H	E	-	B	X	03	S	S	X	-	X	H	X	A	X	P	X	X	P	X	
(12) Brick	-	4	-	H	I	-	C	C	5	5												

Note: the order code is for a B95<sup>plus</sup> system. The B95<sup>plus</sup> provides bus differential protection for 6 zones, annunciator and display, breaker failure protection. IEC 61850 and DNP 3.0 communications, metering, transient fault recording, and 2 process cards to support connections for up to 16 Bricks. This system also includes 12 Bricks with eight 5 A current inputs each.

GE Digital Energy  
2018 Powers Ferry Road  
Atlanta, GA 30339  
Tel: 1-877-605-6777