

IEC 61850 Communication Networks and Systems In Substations: An Overview for Users

Mark Adamiak , Drew Baigent
GE Digital Energy

Ralph Mackiewicz
SISCO

1. Abstract

Over the last decade, the “digitization” of the electron enterprise has grown at exponential rates. Utility, industrial, commercial, and even residential consumers are transforming all aspects of their lives into the digital domain. Moving forward, it is expected that every piece of equipment, every receptacle, every switch, and even every light bulb will possess some type of setting, monitoring and/or control. In order to be able to manage the large number of devices and to enable the various devices to communicate with one another, a new communication model was needed. That model has been developed and standardized as IEC 61850 – Communication Networks and Systems in Substations [1]. This paper looks at the needs of next generation communication systems and provides an overview of the IEC 61850 protocol and how it meets these needs.

2. Communication System Needs

Communication has always played a critical role in the real-time operation of the power system. In the beginning, the telephone was used to communicate line loadings back to the control center as well as to dispatch operators to perform switching operations at substations. Telephone-switching based remote control units were available as early as the 1930’s and were able to provide status and control for a few points. As digital communications became a viable option in the 1960’s, data acquisition systems (DAS) were installed to automatically collect measurement data from the substations. Since bandwidth was limited, DAS communication protocols were optimized to operate over low-bandwidth communication channels. The “cost” of this optimization was the time it took to configure, map, and document the location of the various data bits received by the protocol.

As we move into the digital age, literally thousands of analog and digital data points are available in a single Intelligent Electronic Device (IED) and communication bandwidth is no longer a limiting factor. Substation to master communication data paths operating at 64,000 bits per second are becoming common-place with an obvious migration path to much high rates. With this migration in technology, the “cost” component of a data acquisition system has now become the configuration and documentation component. Consequently, a key component of a communication system is the ability to describe themselves from both a data and services



(communication functions that an IED performs) perspective. Other “key” requirements include:

- High-speed IED to IED communication
- Networkable throughout the utility enterprise
- High-availability
- Guaranteed delivery times
- Standards based
- Multi-vendor interoperability
- Support for Voltage and Current samples data
- Support for File Transfer
- Auto-configurable / configuration support
- Support for security

Given these requirements, work on a “next generation” communication architecture began with the development of the Utility Communication Architecture (UCA) in 1988. The result

of this work was a profile of “recommended” protocols for the various layers of the International Standards Organization (ISO) Open System Interconnect (OSI) communication system model. This architecture resulted in the definition of a “profile” of protocols, data models, and abstract service definitions that became known as UCA. The concepts and fundamental work done in UCA became the foundation for the work done in the IEC TC57 Working Groups 10, 11, and 12 which resulted in the International Standard – IEC 61850 – Communication Networks and Systems in Substations [1].

3. Scope and Outline of IEC 61850

The stated scope of IEC 61850 was communications within the substation. The document defines the various aspects of the substation communication network in 10 major sections as shown in Table 1 below.

Part #	Title
1	Introduction and Overview
2	Glossary of terms
3	General Requirements
4	System and Project Management
5	Communication Requirements for Functions and Device Models
6	Configuration Description Language for Communication in Electrical Substations Related to IEDs
7	Basic Communication Structure for Substation and Feeder Equipment
7.1	- Principles and Models
7.2	- Abstract Communication Service Interface (ACSI)
7.3	- Common Data Classes (CDC)
7.4	- Compatible logical node classes and data classes
8	Specific Communication Service Mapping (SCSM)
8.1	- Mappings to MMS (ISO/IEC 9506 – Part 1 and Part 2) and to ISO/IEC 8802-3
9	Specific Communication Service Mapping (SCSM)
9.1	- Sampled Values over Serial Unidirectional Multidrop Point-to-Point Link
9.2	- Sampled Values over ISO/IEC 8802-3
10	Conformance Testing

Table 1.

Parts 3, 4, and 5 of the standard start by identifying the general and specific functional requirements for communications in a substation (key requirements stated above). These requirements are then used as forcing functions to aid in the identification of the services and data models needed, application protocol required, and the underlying transport, network, data link, and physical layers that will meet the overall requirements.

The major architectural construct that 61850 adopts is that of “abstracting” the definition of the data items and the services, that is, creating data items/objects and services that are independent of any underlying protocols. The abstract definitions then allow “mapping” of the data objects and services to any other protocol that can meet the data and service requirements. The definition of the abstract services is found in part 7.2 of the

standard and the abstraction of the data objects (referred to as Logical Nodes) is found in part 7.4. In as much as many of the data objects are made up of common pieces (such as Status, Control, Measurement, Substitution), the concept of “Common Data Classes” or “CDC” was developed which defined common building blocks for creating the larger data objects. The CDC elements are defined in part 7.3.

Given the data and services abstract definitions, the final step was one of “mapping” the abstract services into an actual protocol. Section 8.1 defines the mapping of the abstract data object and services onto the Manufacturing Messaging Specification – MMS2 and sections 9.1 and 9.2 define the mapping of the Sample Measured Values (unidirectional point-to-point and bi-directional multipoint accordingly) onto an Ethernet data frame. The 9.2 document defines what has become known as the Process Bus.

From a system perspective, there is a significant amount of configuration that is required in order to put all the pieces together and have them work. In order to facilitate this process and to eliminate much of the human error component, an XML based Substation Configuration Language (SCL) was defined in part 6. It allows the formal description of the relations between the substation automation system and the substation (switchyard). At the application level, the switchyard topology itself and the relation of the switchyard structure to the SAS functions (logical nodes) configured on the IEDs can be described. Each device must provide an SCL file that describes the configuration of itself.

Although the scope of IEC 61850 was originally focused “inside” the substation, discussions are underway to look at defining IEC 61850 for the Substation to Master communication protocol (already in service in several installations). In addition, applications are in service that uses various components of IEC 61850 for wide area substation-to-substation communication.

Finally, part 10 of the document defines a testing methodology in order to determine “conformance” with the numerous protocol definitions and constraints defined in the document.

The rest of this paper goes into some focused details of the various parts of the IEC 61850 standard.

4. Modeling Approach

Legacy protocols have typically defined how bytes are transmitted on the wire. However, they did not specify how data should be organized in devices in terms of the application. This approach requires power system engineers to manually configure objects and map them to power system variables and low-level register numbers, index numbers, I/O modules, etc. IEC 61850 is unique. In addition to the specification of the protocol elements (how bytes are transmitted on the wire), IEC 61850 provides a comprehensive model for how power system devices should organize data in a manner that is consistent across all types and brands of devices. This eliminates much of the tedious non-power system configuration effort because the devices can configure themselves. For instance, if you put a CT/VT input into an IEC 61850 relay, the relay can detect this module and automatically assign it to a measurement unit without user interaction. Some devices use an SCL file to configure the objects and the engineer need only import the SCL file into the device to configure it. Then, the IEC 61850 client application can extract the object definitions from the device over the network. The result is a very large savings in the cost and effort to configure an IEC 61850 device.

The IEC 61850 device model begins with a physical device. A physical device is the device that connects to the network. The physical device is typically defined by its network address. Within each physical device, there may be one or more logical devices. The IEC 61850 logical device model allows a single physical device to act as a proxy or gateway for multiple devices thus providing a standard representation of a data concentrator.

Each logical device contains one or more logical nodes. A logical node (see Figure 1) is a named grouping of data and associated services that is logically related to some power system function.

XCBR Class					
DATA NAME	COMMON DATA CLASS	DESCRIPTION	T	MANDATORY/OPTIONAL	
LNName	Secure	Shall be inherited from Logical-Node Class (see IEC 61850-7-2)			
DATA					
Common Logical Node Information					
		LN shall inherit all Mandatory Data from Common Logical Node Class		Mandatory	
Loc	SPS	Local operation (local means without substation automation communication, hardwired direct control)		Mandatory	
EE Health	INS	External equipment health		Optional	
EE Name	DPL	External equipment name plate		Optional	
OpCnt	INS	Operation counter		Mandatory	
Controls					
Pos	DPC	Switch position		Mandatory	
BlkOpn	SPC	Block opening		Mandatory	
BlkCls	SPC	Block closing		Mandatory	
ChaMotEna	SPC	Charger motor enabled		Optional	
Metered Values					
SumSwARs	BCR	Sum o Switched Amperes, resetable		Optional	
Status Information					
CBOpCap	INS	Circuit breaker operating capability		Mandatory	
POWCap	INS	Point on Wave switching capability		Optional	
MaxOpCap	INS	Circuit breaker operating capability when fully charged		Optional	

Figure 1.
Anatomy of Circuit Breaker (XCBR)
Logical Node in IEC 61850-7-4

There are logical nodes for automatic control the names of which all begin with the letter “A”. There are logical nodes for metering and measurement the names of which all begin with the letter “M”. Likewise there are logical nodes for Supervisory Control (C), Generic Functions (G), Interfacing/Archiving (I), System logical nodes (L), Protection (P), Protection Related (R), Sensors (S), Instrument Transformers (T), Switchgear (X), Power Transformers (Y), and Other Equipment (Z). Each logical node has an LN-Instance-ID as a suffix to the logical node name. For instance, suppose there were two measurement inputs in a device to measure two 3-phase feeders. The standard name of the logical node for a Measurement Unit for 3-phase power is MMXU. To delineate between the measurements for these 2 feeders the IEC 61850 logical node names of MMXU1 and MMXU2 would be used. Each logical node may also use an optional application specific LN-prefix to provide further identification of the purpose of a logical node.

Each logical node contains one or more elements of Data. Each element of data has a unique name. These Data Names are determined by the standard and are functionally related to the power system purpose. For instance, a circuit breaker is modeled as an XCBR logical node. It contains a variety of Data including Loc for determining if operation is remote or local, OpCnt for an operations count, Pos for the position, BlkOpn block breaker open commands, BlkCls block breaker close commands, and CBOpCap for the circuit breaker operating capability.

Each element of data within the logical node conforms to the specification of a common data class (CDC) per IEC 61850-7-3. Each CDC describes the type and structure of the data within the logical node. For instance, there are CDCs for status information, measured information, controllable status information, controllable analog set point information, status settings, and analog settings. Each CDC has a defined name and a set of CDC attributes each with a defined name, defined type, and specific purpose. Each individual attribute of a CDC belongs to a set of functional constraints (FC) that groups the attributes into categories. For instance, in the Single Point Status (SPS) CDC described in Figure 2, there are functional constraints for status (ST) attributes, substituted value (SV) attributes, description (DC) attributes, and extended definition (EX) attributes. In this example the status attributes of the SPS class consists of a status value (stVal), a quality flag (q), and a time stamp (t).

SPS Class					
ATTRIBUTE NAME	ATTRIBUTE TYPE	FUNCTIONAL CONSTRAINT	TRGOP	VALUE / VALUE RANGE	MANDATORY/OPTIONAL
DataName	Inherited from Data Class (see IEC 61850-7-2)				
DATA ATTRIBUTE					
Status					
stVal	BOOLEAN	ST	dchg	TRUE FALSE	Mandatory
q	Quality	ST	qchg		Mandatory
t	TimeStamp	ST			Mandatory
Substitution					
subEna	BOOLEAN	SV			PICS_SUBST
subVal	BOOLEAN	SV		TRUE FALSE	PICS_SUBST
subQ	Quality	SV			PICS_SUBST
subID	VISIBLE STRING64	SV			PICS_SUBST
Configuration, description and extension					
d	VISIBLE STRING255	DC		Text	Optional
dU	UNICODE STRING255	DC			Optional
cdcNs	VISIBLE STRING255	EX			AC_DLND_A_M
cdcName	VISIBLE STRING255	EX			AC_DLND_A_M
dataNs	VISIBLE STRING255	EX			AC_DLND_M

Figure 2.
Anatomy of the Single Point Status (SPS)
Common Data Class in IEC 61850-7-3

The IEC 61850 model of a device is a virtualized model that begins with an abstract view of the device and its objects and is defined in IEC 61850 part 7. Then, this abstract model is mapped to a specific protocol stack in section IEC 61850-8-1 based on MMS (ISO9506), TCP/IP, and Ethernet. In the process of mapping the IEC 61850 objects to MMS, IEC 61850-8-1 specifies a method of transforming the model information into a named MMS variable object that results in a unique and unambiguous reference for

each element of data in the model. For instance, suppose that you have a logical device named “Relay1” consisting of a single circuit breaker logical node XCBR1 for which you want to determine if the breaker is in the remote or local mode of operation. To determine this you would read the object shown in Figure 3.

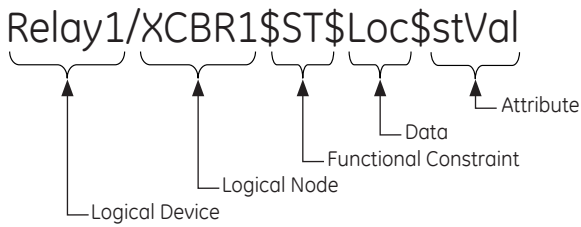

Figure 3.
Anatomy of an IEC 61850-8-1 Object Name

5. Mapping to Real Protocols

The abstract data and object models of IEC 61850 define a standardized method of describing power system devices that enables all IEDs to present data using identical structures that are directly related to their power system function. The Abstract Communication Service Interface (ACSI) models of IEC 61850 define a set of services and the responses to those services that enables all IEDs to behave in an identical manner from the network behavior perspective. While the abstract model is critical to achieving this level of interoperability, these models need to be operated over a real set of protocols that are practical to implement and that can operate within the computing environments commonly found in the power industry. IEC 61850-8-1 maps the abstract objects and services to the Manufacturing Message Specification (MMS) protocols of ISO9506. Why was a protocol originally designed for manufacturing used? Because MMS is the only public (ISO standard) protocol that has a proven implementation track record that can easily support the complex naming and service models of IEC 61850. While you can theoretically map IEC 61850 to any protocol, this mapping can get very complex and cumbersome when trying to map IEC 61850 objects and services to a protocol that only provides read/write/report services for simple variables that are accessed by register numbers or index numbers. This was the reason that MMS was chosen for UCA in 1991 and is the reason that it was kept for IEC 61850. MMS is a very good choice because it supports complex named objects and a rich set of flexible services that supports the mapping to IEC 61850 in a straightforward manner.

The mapping of IEC 61850 object and service models to MMS is based on a service mapping where a specific MMS service/services are chosen as the means to implement the various services of ACSI. For instance, the control model of ACSI is mapped to MMS read and write services. Then the various object models of IEC 61850 are mapped to specific MMS objects. For instance, the IEC 61850 logical device object is mapped to an MMS domain. Table 2 summarizes the mapping of IEC 61850 objects and Table 3 the ACSI mapping to MMS.

In addition to the mapping to the application layer, Part 8.1 defines profiles for the “other” layers of the communication stack that are dependent on the service provided (as shown in Figure 4). Of note on the various profiles: the Sampled Values and GOOSE applications map directly into the Ethernet data frame thereby eliminating processing of any middle layers; the MMS Connection

IEC61850 Objects	MMS Object
SERVER class	Virtual Manufacturing Device (VMD)
LOGICAL DEVICE class	Domain
LOGICAL NODE class	Named Variable
DATA class	Named Variable
DATA-SET class	Named Variable List
SETTING-GROUP-CONTROL-BLOCK class	Named Variable
REPORT-CONTROL-BLOCK class	Named Variable
LOG class	Journal
LOG-CONTROL-BLOCK class	Named Variable
GOOSE-CONTROL-BLOCK class	Named Variable
GSSE-CONTROL-BLOCK class	Named Variable
CONTROL class	Named Variable
Files	Files

Table 2.
IEC 61850 to MMS object mapping

IEC 61850 Services	MMS Services
LogicalDeviceDirectory	GetNameList
GetDataAllValues	Read
GetDataValues	Read
SetDataValues	Write
GetDataDirectory	GetNameList
GetDataDefinition	GetVariableAccessAttributes
GetDataSetValues	Read
DataSetValues	Write
CreateDataSet	CreateNamedVariableList
DeleteDataSet	DeleteNamedVariableList
DataSetDirectory	GetNameList
Report (Buffered and Unbuffered)	InformationReport
GetBRCBValues/GetURCBValues	Read
SetBRCBValues/SetURCBValues	Write
GetLCBValues	Read
SetLCBValues	Write
QueryLogByTime	ReadJournal
QueryLogAfter	ReadJournal
GetLogStatusValues	GetJournalStatus
Select	Read/Write
SelectWithValue	Read/Write
Cancel	Write
Operate	Write
Command-Termination	Write
TimeActivated-Operate	Write
GetFile	FileOpen/FileRead/FileClose
SetFile	ObtainFile
DeleteFile	FileDelete
GetFileAttributeValues	FileDirectory

Table 3.
IEC 61850 services mapping (partial)

Oriented layer can operate over TCP/IP or ISO; the Generic Substation Status Event (GSSE) is the identical implementation as the UCA GOOSE and operates over connectionless ISO services; all data maps onto an Ethernet data frame using either the data type "EtherType" in the case of Sampled Values, GOOSE, TimeSync, and TCP/IP or "802.3" data type for the ISO and GSSE messages.

6. Process Bus

As technology migrates to "next generation" low-energy voltage and current sensors, the ability to digitize the base quantities at the source and transmit the resulting sample values back to the substation becomes a need. In addition to Sampled Values, the ability to remotely acquire status information as well as set output controls is very desirable. IEC 61850 addresses this need through the definition of Sampled Measured Values services and the implementation of a Process Bus. The Process layer of the substation is related to gathering information, such as Voltage, Current, and status information, from the transformers and transducers connected to the primary power system process – the transmission of electricity. IEC 61850 defines the collection of this data via two different protocol definitions, namely, Part 9.1 which defines a Unidirectional Multidrop Point-to-Point fixed link carrying a fixed dataset and Part 9.2 which defines a "configurable" dataset that can be transmitted on a multi-cast basis from one publisher to multiple subscribers.

Figure 5, above, shows the basic concept of the Process Bus. Signals from voltage and current sources (low or high energy) as well as status information are input into a "Merging Unit" (MU).

The Merging Units in a station sample the signals at an agreed, synchronized rate. In this manner, any IED can input data from multiple MUs and automatically align and process the data. At this time, there is an implementation agreement that defines a base sample rate of 80 samples per power system cycle for basic protection and monitoring and a "high" rate of 256 samples per power system cycle for high-frequency applications such as power quality and high-resolution oscillography.

Part 9.1 specifies a pre-configured or "universal" dataset as defined in IEC 60044-8. This dataset includes 3-phase voltage, bus voltage, neutral voltage, 3-phase currents for protection, 3-phase currents for measurement and two 16-bit status words. Note that the analog data values are mapped into 16-bit registers in this mapping.

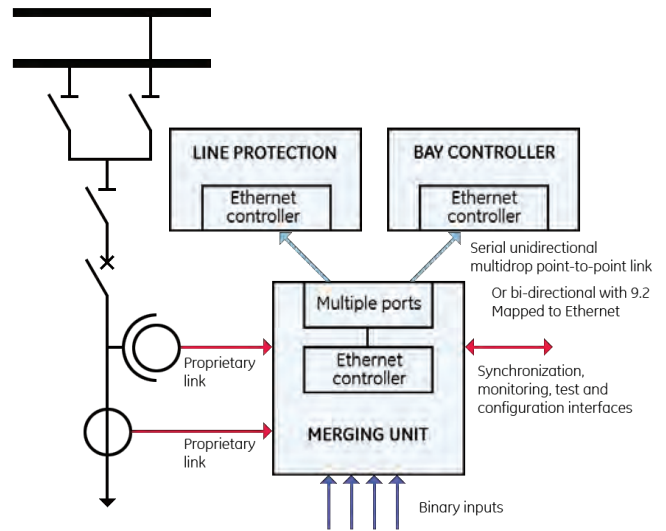

Figure 5.
Sample Measured Value Concept

Part 9.2 is a more generalized implementation of Sampled Measured Values (SMV) data transfer. In 9.2, the dataset or "payload" is user-defined using the SCL. As a dataset, data values of various sizes and types can be integrated together. Note that the existing implementation agreement proposed a data value size of 32 bits with a scale factor of 1 count = 1ma.

Both 9.1 and 9.2 specify mapping directly onto an Ethernet transport (see Figure 4). Depending on the sample data rate, anywhere from 1 to 5 devices can be mapped onto a single 100MB Ethernet link. Multiple 100MB Ethernet data streams can then be

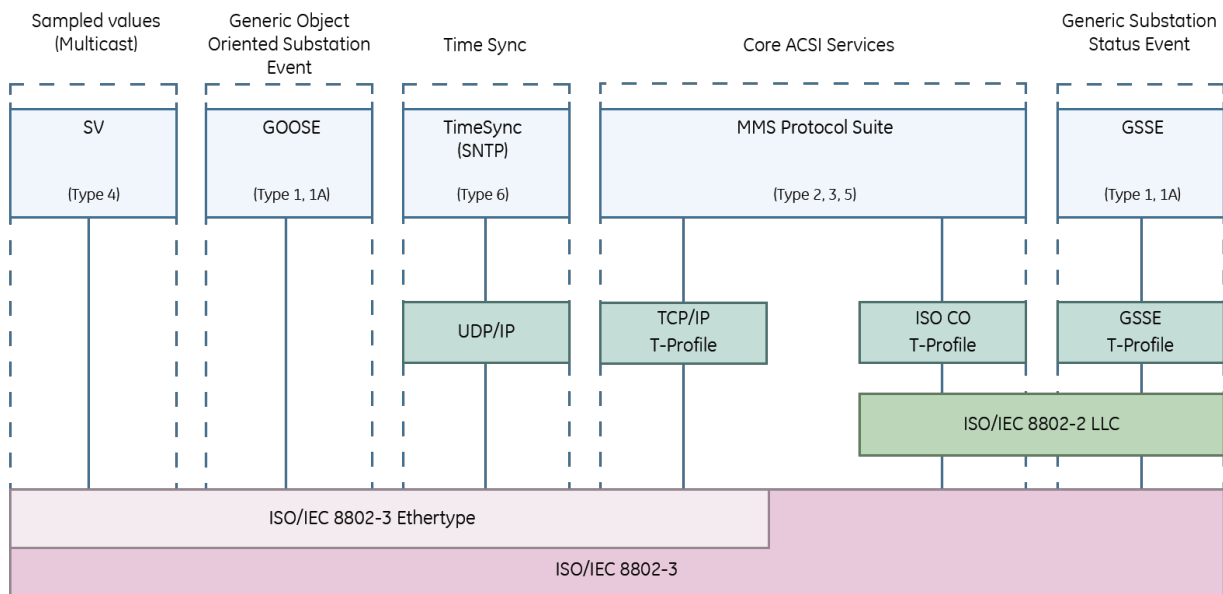

Figure 4.
Overview of IEC 61850 Functionality and Associated Communication Profiles

combined into a single Ethernet switch with a 1GB backbone. In this configuration, 50 or more datasets can be published to multiple subscribers.

7. Substation Configuration Language

IEC 61850-6-1 specifies a Substation Configuration Language (SCL) that is based on the eXtensible Markup Language (XML) to describe the configuration of IEC 61850 based systems. SCL specifies a hierarchy of configuration files that enable multiple levels of the system to be described in unambiguous and standardized XML files. The various SCL files include system specification description (SSD), IED capability description (ICD), substation configuration description (SCD), and configured IED description (CID) files. All these files are constructed in the same methods and format but have different scopes depending on the need.

Even though an IEC 61850 client can extract an IED's configuration from the IED when it is connected to that IED over a network, there are several scenarios where the availability of a formal off-line description language can bring very large benefits to users outside of configuring IEC 61850 client applications. These benefits include:

- SCL enables off-line system development tools to generate the files needed for IED configuration automatically from the power system design significantly reducing the cost and effort of IED configuration by eliminating most, if not all, manual configuration tasks.
- SCL enables the sharing of IED configuration among users and suppliers to reduce or eliminate inconsistencies and misunderstandings in system configuration and system requirements. Users can provide their own SCL files to ensure that IEDs are delivered to them properly configured.
- SCL allows IEC 61850 applications to be configured off-line without requiring a network connection to the IED for client configuration.

SCL can be used as best fits each user's requirements. A user can decide to use CID files to provide help in IED configuration using its existing system design processes. Or SCL can be used to restructure the entire power system design process to eliminate manual configuration, eliminate manual data entry errors, reduce misunderstanding between system capabilities and requirements, enhance the interoperability of the end system, and greatly increase the productivity and effectiveness of power system engineers.

8. IEC Substation Model

Putting the pieces together results in the substation architecture shown in Figure 6.

At the "process" layer, data from Optical/Electronic Voltage and Current sensors as well as status information will be collected and digitized by the Merging Units (MUs). MUs could be physically located either in the field or in the control house. Data from the MUs will be collected through redundant 100MB fiber optic Ethernet connections. The collection points will be redundant Ethernet switches with 1GB internal data buses and 1GB uplinks that support Ethernet priority and Ethernet Virtual LAN (VLAN).

VLAN allows the Ethernet switch to deliver datasets to only those switch ports/IEDs that have subscribed to the data. In migrating to Process Bus implementations, manufacturers will need to provide the ability to integrate data from existing CTs and PTs with the data from the newer Optical/Electronic sensors. A redundant synchronization clock architecture will also have to be addressed. In this architecture, upon detection of failure of Clock 1, Clock 2 will have to automatically come on line and continue providing sampling synchronization.

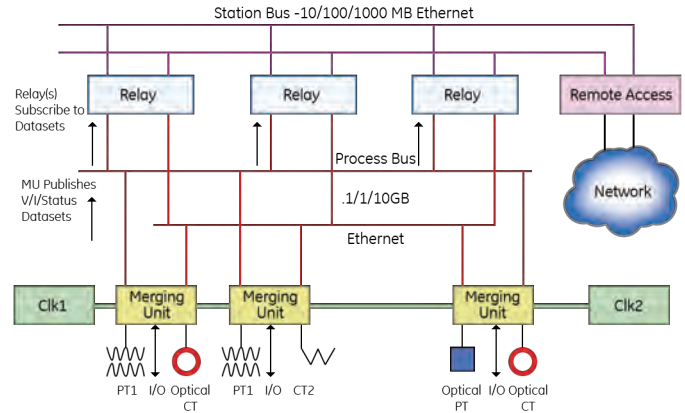

Figure 6.
IEC 61850 Substation Model

At the substation level, a Station Bus will exist. Again, this bus will be based today on 10MB Ethernet with a clear migration path to 100MB Ethernet. The Station Bus will provide primary communications between the various Logical Nodes, which provide the various station protection, control, monitoring, and logging functions. Communications will operate on either a connection oriented basis (e.g. – request of information, configuration, etc.) or a connection-less basis (IEC Generic Object Oriented Substation Event - GOOSE). Again, a redundant communication architecture is recommended as application of IED to IED data transmission puts the communication system on the critical path in case of a failure.

Finally, this architecture supports remote network access for all types of data reads and writes. As all communication is network enabled, multiple remote "clients" will desire access the wide variety of available information. Typical clients would include local HMI, operations, maintenance, engineering, and planning. The remote access point is one logical location to implement security functions such as encryption and authentication. This implementation un-burdens the individual IEDs from performing encryption on internal data transfers but still provide security on all external transactions.

9. Application Software

A variety of commercial products supporting IEC 61850 are already available and the future holds promise for many new innovations that will greatly benefit users. Of particular significance are products that support both the IEC 61850 communications standard and the OLE for Process Control (OPC see <http://www.opcfoundation.org>) application program interface (API) standard of the OPC Foundation. The combination of a standardized protocol and a standardized API is a powerful tool that allows users to dramatically lower their costs to build substation automation

systems by enabling products from different vendors to plug together into a complete solution.

The OPC Data Access (DA) specification is an API that enables an OPC Client application, such as a SCADA or Human Machine Interface (HMI) application, to provide a generic interface to outside data that is independent of any specific protocol (Figure 7). This enables third parties to develop OPC Servers to interface with a wide variety of protocols, including IEC 61850, Modbus, DNP3, and hundreds of other protocols. There is a wide availability of both client and server applications that provide users choice and flexibility. For instance, interfaces to many different applications like relational data base management systems (RDBMS), spreadsheets, data historians, trending systems, etc. are available that support OPC and provide a large choice of options to implement complex systems at a low cost (see Figure 8).

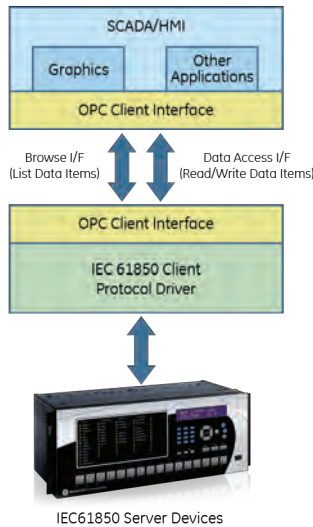

Figure 7.
Using IEC 61850 with OPC

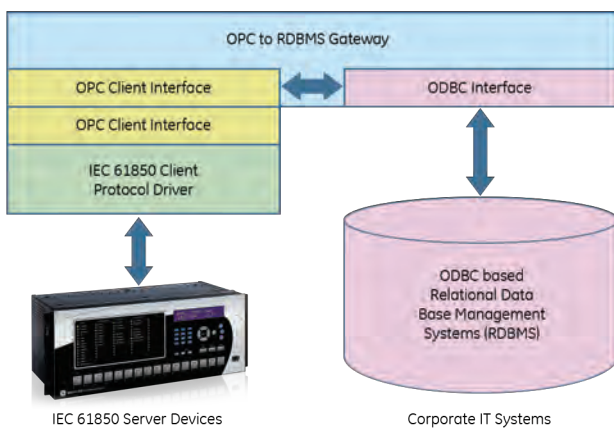

Figure 8.
OPC Enables IEC 61850 Interface to IT

In addition to providing access to data in IEDs, OPC interfaces support an important feature called browsing. The OPC browse interface enables the client to retrieve the list of data items defined in a server instead of having to be pre-configured. This works especially well with IEC 61850 devices because of built-in support for object discovery. By combining OPC with IEC 61850 the substation engineer avoids many hours of configuration and

is able to install and commission systems quicker with less effort and fewer errors resulting in lower costs.

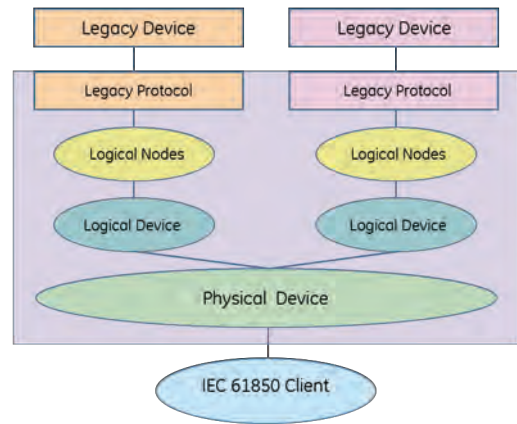

Figure 9.
IEC 61850 Data concentrator Architecture

9.1 Interface with Legacy Protocols

Electric power systems are designed to last for many years. For any new technology to be successfully applied into a modern power system, there must be some way to accommodate the use of legacy IEDs and protocols from the past. IEC 61850 is no different and there are several methods for accommodating legacy protocols in an IEC 61850 system. IEC 61850 itself is well suited to accommodate legacy protocols with its logical device model. The ability to support multiple logical devices within a single physical device allows IEC 61850 to directly support the modeling of a data concentrator or multi-device gateway inherently without resorting to techniques outside the scope of the standard. Data concentrator devices (Figure 9) supporting the IEC 61850 logical device model are available with new products under development. In addition to the use of separate data concentrators, OPC technology also offers a way to incorporate simple gateway functionality into a substation SCADA system (Figure 10). In this case, the roles of OPC client and server are reversed from the previous example illustrating a substation SCADA application by building an OPC client application on top of an IEC 61850 server. The OPC client is then mapped to an OPC server supporting any legacy or proprietary protocol. This enables data from legacy devices to be accessed as IEC 61850 data simplifying the client application development by providing a consistent standardized mechanism for data access across the entire substation.

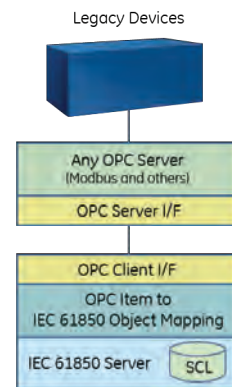

Figure 10.
IEC 61850 Data Gateways using OPC

10. Conclusions

IEC 61850 is now released to the industry. Nine out of ten parts of the standard are now International Standards (part 10 on testing is in the CDV stage). This standard addresses most of the issues that migration to the digital world entails, especially, standardization of data names, creation of a comprehensive set of services, implementation over standard protocols and hardware, and definition of a process bus. Multi-vendor interoperability has been demonstrated and compliance certification processes are being established. Discussions are underway to utilize IEC 61850 as the substation to control center communication protocol. IEC 61850 will become the protocol of choice as utilities migrate to network solutions for the substations and beyond.

11. References

- [1] IEC 61850 - Communication Networks and Systems in Substations; <http://domino.iec.ch/webstore/webstore.nsf/searchview/?SearchView=&SearchOrder=4&SearchWV=TRUE&SearchMax=1000&Query=61850&submit=OK>
- [2] Manufacturing Messaging Specification; ISO 9506-1&2:2003; Part 1 – Service Definition: Part 2 – Protocol Specification