

Products and technology

Serving two worlds

DANEO 400: Our new portable measurement system that measures, records, and analyzes all signals in a substation

In modern protection and automation systems with IEC 61850 communication, the activities in the communication network play a vital role. The proper function and coordination of both, the conventional signals (voltages, currents, hardwired binary status signals) and the messages exchanged on the communication network, are indispensable.

Our new DANEO 400 is a substation signal analyzer for conventional and network signals that measures signals from both of these worlds, and can thus provide information to assess the proper coordination. You can keep track of what is going on in the substation by obtaining information on the operational status and communication. Regardless of whether you are a SAS (Substation Automation System) vendor or builder, troubleshooter in maintenance departments of utilities, test engineer responsible for commissioning protection and control devices, or a communication networking specialist: you will benefit from this convenient and versatile system.

One device—multiple applications

DANEO 400 covers a wide range of tasks in different applications, such as Factory Acceptance Tests (FATs) and Site Acceptance Tests (SATs), end-to-end communication testing, troubleshooting, and commissioning.

Due to its multiple, precise time synchronization, DANEO 400 can form a distributed measurement and recording system. Not only does it allow you to see the relationships between signals of a different nature, but it also facilitates time synchronized signal measurements at multiple locations in the SAS.

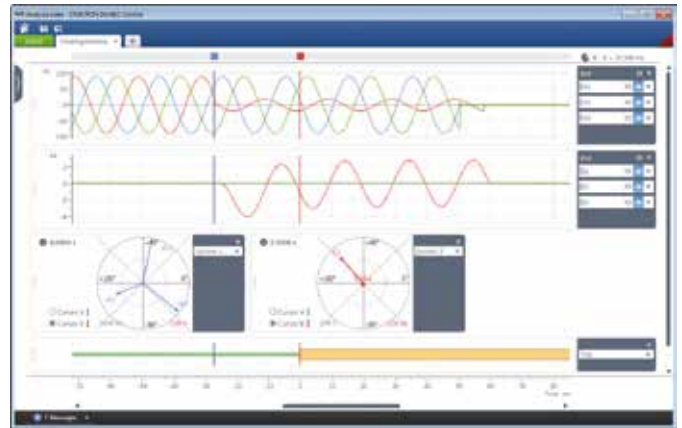

Analysis of a power system event.

Moreover, the device can be left unattended on site. If a trigger occurs, the signals are recorded and the recordings are saved to a mass storage device. Then, the device re-arms itself and waits for the next trigger.

Furthermore, several network related functions are accessible via a web interface and can be used from any device with a suitable web browser. Therefore, you have immediate access to networking functions that will help you in improvised testing situations. This works even for protocols outside the context of IEC 61850.

DANEO 400 in FAT and SAT applications

The outcome of test cases performed during FATs and SATs can be verified, proofed, and documented with DANEO 400. In case of a malfunction, the device provides information for debugging. For both applications, saving the recorded data and documenting the measurements are especially relevant. DANEO 400 verifies SCL information with the actual configuration "as found" and checks if all GOOSE messages and SV streams are present on the network as described in the SCD file, which serves as the

basis for the test. You can also measure the propagation delay for GOOSE and SV in the substation network and assess the network load.

DANEO 400 for commissioning

DANEO 400 is also a valuable tool for various applications in the field of commissioning.

As a test engineer in charge of commissioning protection and control devices, you can verify, proof and document that all the commissioned protection and control devices are working and communicating properly. If the devices do not perform as desired, DANEO 400 supports the debugging process.

As a communication engineer dedicated to the commissioning of the substation communication network, you can assess the performance of the substation communication network itself, even if there are no devices connected. Enhanced tests like the distributed measurement of packet timings in the communication network will be simplified as much as possible with it. Having the proper functions of the communication network verified is an important precondition for the optimum performance of a SAS.

DANEO 400 for distributed testing in a substation-to-substation scenario

To verify proper inter-substation communication, you can measure and assess the transfer of status information between substations with DANEO 400. The remote test sets are configured and controlled over the WAN. With DANEO 400 you measure the performance of the ▶

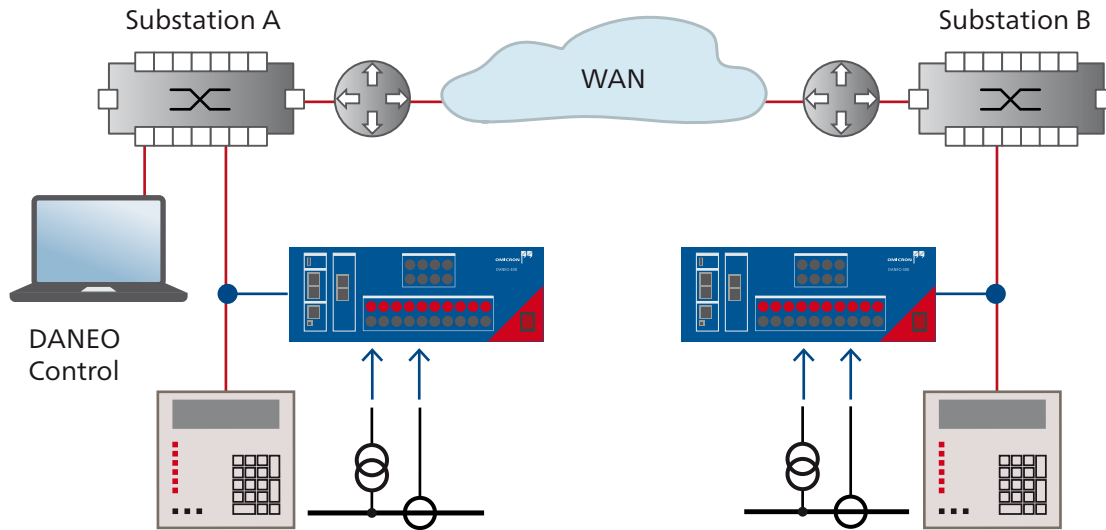

DANE0 400 for distributed testing in a substation-to-substation scenario.

DANE0 400

- > Distributed recording with multiple units
- > Time synchronized measurements
- > Aggregated and time-aligned presentation of results
- > Analog voltages and currents
- > Hardwired binary signals
- > IEC 61850 GOOSE
- > IEC 61850 Sampled Values (9-2LE @ 0SPC)
- > Any traffic on the substation communication network



► communication path (by evaluating the propagation of the GOOSE messages) and the effective information transfer at process level (by assessing the changes in the analog and binary signals).

DANE0 400 for troubleshooting

Maintenance engineers have to trace problems in a substation that occur infrequently and under conditions which are not always known. The troubleshooter must react to a situation without any preparation and needs to be able to improvise without having access to the full documentation of the SAS. Nevertheless, there is often a lot of pressure to resolve such issues and DANE0 400 can help give the engineer clues to what may be causing the SAS to malfunction.

For this application, the measuring device is wired up to the signals of interest (voltages, currents, binary status signals, substation communication traffic) and set up with a trigger condition. If large amounts of data are expected, an external hard drive can be connected for dumping the recordings.

When remote access is possible, the status of the device can be checked. If the bandwidth is appropriate, recordings can be downloaded for analysis. ▣

🌐 www.omicron.at/daneo400

Fred Steinhauser
Product Manager