

# Case Study: IEC 61850 Application for a Transmission Substation in Ghana

Charles E. Anderson, *Meade Electric Company, Inc.*

Salim Zniber, Youssef Botza, David Dolezilek, and Justin McDevitt, *Schweitzer Engineering Laboratories, Inc.*

**Abstract**—One of the benefits of implementing IEC 61850 is minimizing or even eliminating the copper field wiring used to exchange protection and control data between intelligent electronic devices (IEDs) across a substation. Conversely, implementing IEC 61850 has introduced commissioning, testing, and maintenance complexity that can be alleviated with proper training, documentation, and testing plans.

The design and implementation of the Kintampo, Ghana, transmission substation required redundant protection and control functions distributed among the IEDs and a robust communications network to implement IEC 61850 protocols. In order to maintain a high level of availability, the power supplies of the primary and backup protection devices are fed from two separate battery chargers that also feed dual trip coils for the 161 kV high-voltage ac breakers. The use of dual main protection schemes in both distance and differential protective relays and single-pole tripping and reclosing on the transmission line enhances the availability, stability, and reliability of the transmission system. Outdoor equipment mounted in enclosures near the breakers collects and reports breaker and motor-operated disconnect (MOD) alarms and statuses, as well as provides MOD and transmission line ground switch control.

The Kintampo substation has a robust and reliable substation automation system (SAS) that includes a human-machine interface (HMI) for local indication and control, a supervisory control and data acquisition (SCADA) server to provide status, metering, and control data to the local HMI and remote utility enterprise system, and a hardened Ethernet network of industrial-grade switches for reliable communications that can support critical, high-speed protection schemes.

The Ethernet network uses a ring topology with Rapid Spanning Tree Protocol (RSTP) and virtual local-area networks (VLANs) to provide network redundancy, reliability, data segregation, and traffic control. The SAS uses the Manufacturing Message Specification (MMS) and Generic Object-Oriented Substation Event (GOOSE) communications protocols from the IEC 61850 communications standard for data acquisition and control and for high-speed, peer-to-peer protection schemes.

This paper discusses several key aspects of the electrical design, protection and control, communications network design, testing, and commissioning of an IEC 61850-based substation.

## I. INTRODUCTION

Ghana is undergoing major electrical upgrades affecting all aspects of the power system, from generation to transmission and distribution. The Kintampo substation will transmit and distribute 400 MW of power generated at the Bui power plant to hundreds of communities throughout Ghana. Two hundred

and sixteen of these communities are being electrified for the first time as part of the Self-Help Electrification Program (SHEP). This paper documents the innovative use of international standard communication with modern Ethernet network designs to protect, control, and monitor the 161 kV/34.5 kV substation.

With the rapid growth and understanding of the IEC 61850 communications standard, the local utility required several of the protocols and methods defined within the standard to be implemented in this substation for several reasons. The primary reason was to minimize the copper connections between the field and the control house. This was effectively accomplished by using digital messaging over fiber cables to act as virtual wiring among networked intelligent electronic devices (IEDs). Substation wiring practices vary depending on the voltage level, although the number of wires (i.e., the total number of points being measured and controlled) is relatively constant between components. The wire length and number of data paths are significantly reduced by locating the protection and control equipment in the yard [1]. This reduces the amount of material and labor involved and also makes it much easier to verify the wiring correctness, resulting in significant time savings during installation.

Another important reason that a design based on networked IEDs was chosen was to take advantage of additional tangible and intangible benefits. These benefits are based largely on the fact that the IEDs create and contain well organized and accurate data about the IEDs and primary equipment. IEDs also have the processing, memory, and communications capabilities to convert the data into information about the health and performance of the power system. The ability of IEDs to test their own health, store sequence of events (SOE) reports, and provide asset details and firmware information on request makes previously tedious processes simpler and automatic. From a communications and configuration perspective, one of the greatest engineering benefits is the self-documenting capability of the IEC 61850 Substation Configuration Language (SCL) files stored directly in these IEDs. The encapsulation within an IED of a data model that universally describes each piece of substation data and its attributes is one of the greatest advantages this technology has to offer.

## II. PROTECTION AND CONTROL

The Kintampo substation is composed of two substation yards. One is a 161 kV transmission substation with four transmission lines, two step-down transformers, and nine circuit breakers arranged in a breaker-and-a-half scheme. The other is a 34.5 kV distribution substation consisting of two incoming feeds arranged in a main-tie-main scheme with eight feeders. The two stations are connected with underground cables and are several hundred meters apart. The one-line diagram for the transmission substation is shown in Fig. 1.

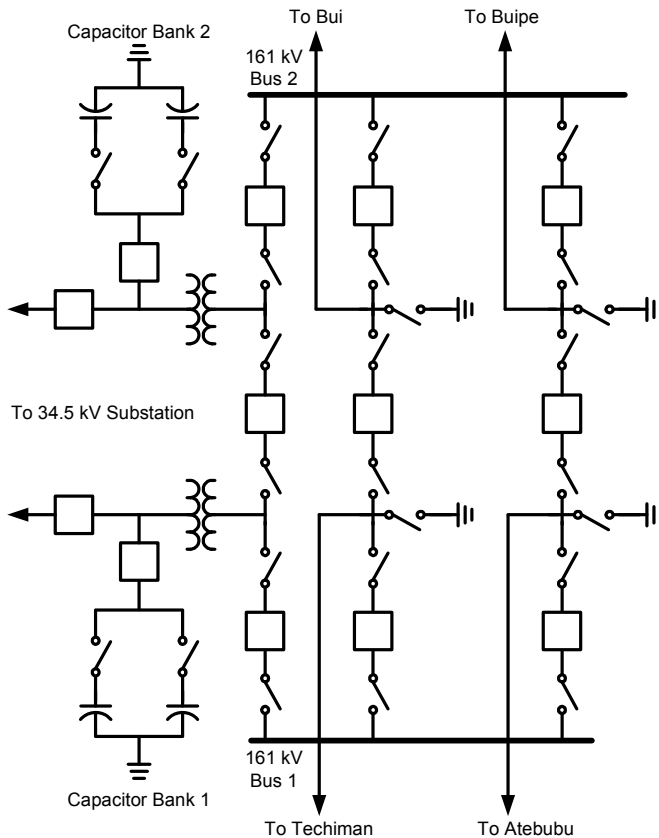

Fig. 1. Kintampo transmission substation one-line diagram.

The electrical arrangement in the transmission substation provides operational flexibility. When the transmission substation is normally operated with each circuit breaker closed, the loss of one transformer, transmission line, or 161 kV bus does not impact the distribution power flow. However, the design requires more complex protection and control schemes. Redundant protection is provided throughout the substation by using primary and backup protection IEDs. The IEDs are powered with separate dc circuits and backup battery systems. Each circuit breaker features single- and three-pole tripping capability with redundant trip coils for each phase. The primary IED trips Trip Coil 1 while the backup IED trips the circuit breaker via Trip Coil 2.

This paper focuses on the communications aspects of the system. The protection applications are out of scope but are generally consistent with traditional methods of accelerating protection applications by sharing information between IEDs.

The sophisticated protection and control schemes at Kintampo depend on reliable and deterministic communications to constantly move data between IEDs. These data were formerly conveyed by hard-wiring a physical output of the source IED to a physical input of the destination IED using copper conductors. IED communications are accomplished via Generic Object-Oriented Substation Event (GOOSE) messages between the source IED and one or more destination IEDs. This requires careful configuration of GOOSE messages within the IEDs and information on where to deliver the messages within the Ethernet switches. GOOSE messages are multicast, meaning that they can be delivered to many IED receivers. However, without proper local-area network (LAN) configuration, multicast messages are sent to every single device in the system. These GOOSE messages support protection and control functions such as circuit breaker failure, GOOSE test mode, and reclose initiate. Perhaps most important is that this message exchange is constantly supervised by each receiving IED in order to immediately detect message delivery problems. If problems occur, the receiving IEDs revert to noncommunications-assisted logic and alert technicians to the problem.

### A. Breaker Failure Communications

The dual primary IEDs controlling each transmission line circuit breaker and the transformer protection IED controlling the transformer circuit breaker also perform breaker failure protection. GOOSE messages transport indications of the change of state of Boolean data such as breaker status, analog values such as metering, and bit strings. The receiving IEDs then interpret and act on the indications that are immediately appropriate to their condition and other logic and inputs. In this way, GOOSE data are not direct trip commands but are rather indications of the remote statuses that are used in trip equations. Communication of information among various IEDs is needed in two stages of breaker failure protection: indication of breaker failure initiation and breaker failure trip indication from the source IED, transmitted to the appropriate relays. Also, in cases where single- and three-pole operations are both possible, indications for both operations are conveyed within the GOOSE message. In cases where the backup IED trips the circuit breaker prior to the primary IED asserting a trip, the backup sends either a single-pole breaker failure initiate or a three-pole breaker failure initiate, depending on the type of fault, to the primary relay.

Once the breaker failure initiate is received, the primary relay starts a 12-cycle timer. If the circuit breaker still has not interrupted the fault once the timer expires, the primary IED declares a breaker failure and sends a trip indication to the surrounding relays within a GOOSE message. The receiving IEDs act on this indication to trip their circuit breakers in order to isolate the faulted circuit breaker. In the Kintampo substation, both the primary and backup relays also receive breaker failure trip indications from the surrounding IEDs, including the relays protecting the 161 kV bus, the opposite transmission line, the adjacent transmission line, and the transformer.

### B. GOOSE Test Mode Communications

In order to test or commission a relay without affecting the other IEDs within the substation, a GOOSE test mode latch bit was programmed into each relay. The latch is enabled with a pushbutton on the front panel of the relay or with a remote bit from the human-machine interface (HMI) and is included in the outgoing GOOSE message. When the latch is enabled, a user can test the relay protection elements and communication with other relays in the zone without causing any of the other circuit breakers to operate. The relay supervises the latched bit in its own logic and publishes the bit in its outgoing GOOSE publications. The receiving relays accept the test mode indication within the GOOSE message and are consequently programmed to block some functionality during testing to avoid inadvertent operation. For example, if the GOOSE test mode is enabled in one relay, the other relays in the zone receive indication of this via GOOSE test mode indication being set to true in the GOOSE message. Therefore, when the GOOSE test mode indication is used as a permissive to block logic, as shown in Fig. 2, data received from the tested relay are updated but not acted upon in the receiving IEDs. If breaker failure asserts from a relay that is in GOOSE breaker failure test mode, the other relays that would normally trip on a breaker failure condition will not operate. However, the other relays still receive a breaker failure and GOOSE test mode indication, which can be verified via the front-panel display. In order to provide isolation of individual protection functions, GOOSE test mode indications are created for each unique protection function to be tested.

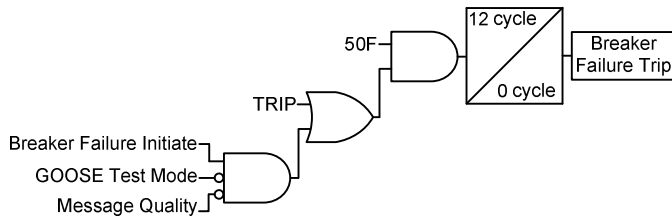

Fig. 2. Breaker failure trip logic.

### C. Reclose Initiate Communications

For the transmission line protection in the substation, the Main 1 relay is used as the primary recloser, while the Main 2 relay is used as the backup recloser. Main 2 reclosing is enabled only when the Main 2 relay detects failure of communication from the Main 1 relay, which may mean that the Main 1 relay is out of service. However, due to the nondeterministic nature of Ethernet, failed GOOSE reception may indicate failed Ethernet cables or Ethernet switches as well as a failed relay. If the Main 1 relay is not failed but GOOSE reception from it is, both main relays can initiate reclosing. Failed GOOSE reception at one relay does not necessarily mean that other relays are not receiving the multicast GOOSE messages.

The overall reclosing design considers both single- and three-pole tripping conditions. Reclosing is initiated by both main relays for single-phase and multi-phase faults detected by the distance elements, pilot scheme, overcurrent elements, or line current differential. Reclosing is set for one shot for single pole followed by one shot for three pole. For a line-to-ground fault, the primary relay performs a single-pole trip and reclose. If the fault is still present after the single-pole reclose, the relay initiates three-pole tripping. The open time interval for the three-pole trip is 900 cycles (15 seconds). If the initial fault involved multiple phases, the relay initiates a three-pole trip and only attempts a single three-pole reclose if the fault is still present. After the reclose and if the fault is still present, the relay performs a three-pole trip and the recloser is driven to lockout.

Because the Main 2 relay can trip the circuit breaker without the primary relay asserting a trip, a reclose initiate indication is sent via GOOSE messaging from the Main 2 relay to the Main 1 relay. The Main 1 relay then initiates the appropriate reclosing sequence depending on whether the received indication is a single- or multi-phase reclose.

### III. EXISTING SUBSTATION WIRING VERSUS NEW PRACTICES

Substation wiring practices vary depending on the voltage level, equipment age, and associated apparatus technology. Traditionally, copper is the primary interface between components in the yard and a relay that is centrally located within a control house. Evaluation of traditional in-service installations finds that there are typically 44 conductors between the field and a relay in a control house. Normally, several multiconductor cables are used; separate cables are typically installed for breaker status (trip/close) and current transformer (CT) and potential transformer (PT) secondaries. Wiring runs are fairly long, spanning between 200 and 500 meters, as shown in Fig. 3.



Fig. 3. Copper conductors removed from cable trenches and replaced by digital messaging.

The horizontal data paths for information exchange between components, labeled “wires” in Fig. 4, represent pairs of copper wires conducting real-time state, binary, and analog measurement information. In this case, each data path includes a data source on the left and a data client on the right.

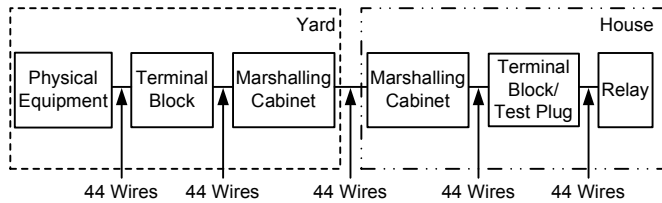

Fig. 4. Traditional wiring approach with relays in the control house.

Although the number of wires (i.e., the total number of points being measured and controlled) is relatively constant between components, the wire length and number of data paths are significantly reduced by locating the protection and control equipment in the yard, as shown in Fig. 5 [1]. This reduces the amount of material and labor involved and also makes it much easier to verify the wiring correctness, resulting in significant time savings during installation.

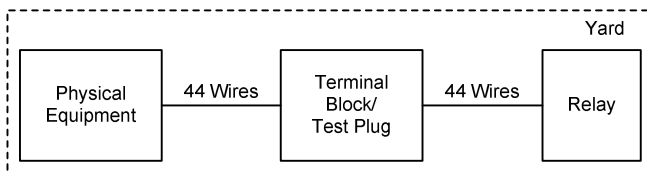

Fig. 5. Wiring approach for relays in the yard.

Locating microprocessor-based relays in the yard significantly improves overall functionality, reduces size, and simplifies internal cabinet wiring. However, care must be taken to select IEDs that are designed for the harsh environment of outdoor installation, as demonstrated by stringent environmental ratings and long manufacturer warranties.

Even without moving the relay to the yard, digital communication of digital I/O greatly simplifies installations. Over 50 percent of the wires within the data path from the yard to the house are associated with circuit breaker control signals. It is therefore advantageous to use a hybrid approach in which the CT and PT wiring is retained, but the control wiring is replaced with a fiber-optic-based I/O transceiver module and communications cable, as shown in Fig. 6.

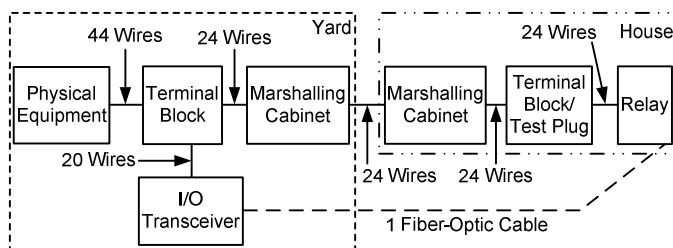

Fig. 6. Hybrid project showing the amount of copper wire replaced with fiber-optic-based I/O module technology.

The I/O module approach provides significant wire savings and introduces the ability to monitor the health of the data connection. This practice has been field-proven for more than a decade based on purpose-built digital communications standards created by standards-related organizations (SROs) and offered via a “reasonable and nondiscriminatory” license, such as MIRRORING BITS<sup>®</sup> communications. Also, protocols created by standards development organizations (SDOs), such as the IEEE and IEC, are useful. One of the two forms of standardized IEC 61850 GOOSE messages has been used in the field for over a decade, and other standards are in use, such as IEEE C37.94. As mentioned, devices use the connection health status to supervise the digital data path and differentiate between silence due to inactivity and silence due to a severed conductor. Reliability is improved because the number of unsupervised components, processes, apparatuses, and data paths is reduced. I/O modules minimize the number of unsupervised data paths between field sources and component data clients. This approach vastly improves the value of the data by confirming the availability and reliability of the methods by which they are collected and by alarming when a data path is broken. Finally, fiber-optic cables also offer galvanic isolation of the data paths between components.

Substation wiring reduction is accomplished in the Kintampo substation via the IEC 61850 real-time GOOSE protocol that is specifically optimized for reliable and timely data transmission. Its use is best understood by reviewing the digital I/O wiring reduction example. Fig. 6 illustrates a straightforward approach of using IEC 61850 GOOSE to digitize and transmit bidirectional information between equipment in the substation yard and the controller in the control house.

Based on user preference, other designs involve moving the entire relay out into the field kiosk, as shown in Fig. 7 [2]. This illustrates a simple way to communicate data between a relay installed in the field kiosk and a station controller installed in the control house.

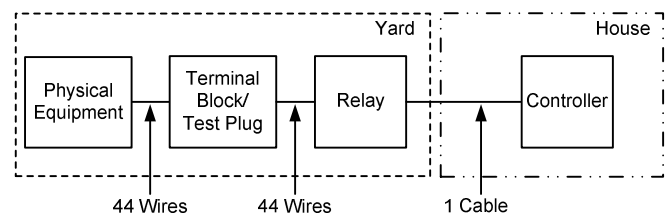

Fig. 7. Simplified diagram showing cable reduction potential with Ethernet-based virtual wiring technology.

While conceptually very simple, the design in Fig. 7 does not take full advantage of the Ethernet network capabilities. The Ethernet link between the relay and controller in the control house is installed as a dedicated, point-to-point interface.

A general interoperable standards-based approach with an Ethernet switch, LAN, and communications among several devices is shown in Fig. 8.

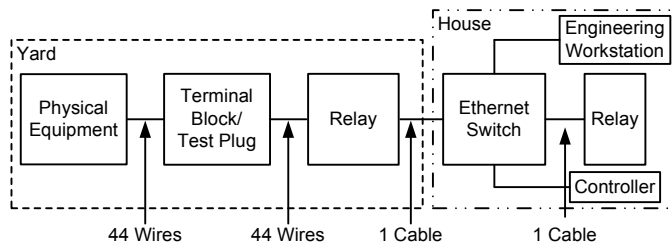

Fig. 8. Ethernet-based relay installation with an Ethernet switch.

#### IV. MOTOR-OPERATED DISCONNECT SWITCHES AND CIRCUIT BREAKER ALARM FIELD IEDS

The modern prefabricated field kiosks and modular control houses used for Kintampo follow the design separation shown in Fig. 6. Everything necessary for the yard application is preinstalled in a prefabricated field kiosk, and all items ordinarily installed in a site-built house are preinstalled in a prefabricated control building. This pre-engineered method greatly reduces overall project time.

This option was ultimately chosen for Kintampo because it simplifies the procurement and installation process dramatically and simplifies site preparation and commissioning. The system became a repeatable, pre-engineered, and pretested solution designed to user specifications in a way similar to primary equipment.

The user requirements were such that circuit breaker control was implemented using a control switch module with indication located in the control house hard-wired to the yard circuit breaker, as shown in Fig. 9.

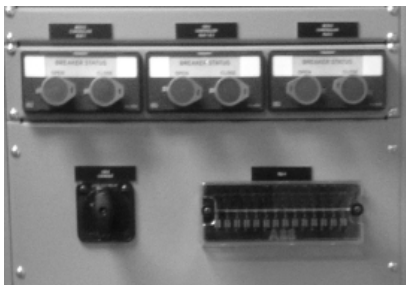

Fig. 9. Control switch module with indication located in the control house.

Circuit breaker alarms and the control and status of the motor-operated disconnects (MODs) are hard-wired to outdoor equipment mounted in enclosures and communicated via IEC 61850 messages over fiber-optic cable as indicated in Fig. 6 and illustrated in Fig. 10. This eliminated significant amounts of wiring between the yard and the control house. Circuit breaker alarms, including SF6 low pressure, control switch in remote, and trip coil monitoring, are reported to the HMI from the field kiosk IEDs using the IEC 61850 poll-and-response Manufacturing Message Specification (MMS) protocol.

Moreover, MOD control trip and close are implemented by wiring the control switch module output to an input on its associated breaker relay in the same panel. Once the input

asserts, the relay in the control house sends a GOOSE message to the outdoor equipment to perform the appropriate action to trip or close and then sends the MOD status back to the HMI and relay. The relay then, in turn, provides an output contact to an input in the control module to provide indication.

Ground switches located near the transmission line circuit breakers have their open/close indication wired to the outdoor equipment. This information is also sent to the circuit breaker control logic inside the control house relays via GOOSE to prevent closing the circuit breaker once the ground switch is closed.



Fig. 10. Typical IED field kiosk installation.

#### V. ETHERNET DESIGN AND CONSIDERATIONS

Ethernet has found a place in safety-critical industrial systems and mission-critical substation networks. Any discussion of Ethernet (which defines the physical and data link layers of the seven-layer Open Systems Interconnection [OSI] communications model) is incomplete without including network topologies and higher-layer protocols created by SROs and SDOs, such as the IEEE and IEC. In the power system industry, Ethernet is often identified with the IEC 61850 set of protocols, as well as IEEE C37.118 synchrophasor transmission and supervisory control and data acquisition-only (SCADA-only) protocols such as DNP3/IP and IEC 60870-5-104. Unlike the message path of serial direct messages, which follow the same path as the physical cabling between devices, Ethernet messages travel paths dictated by methods such as Rapid Spanning Tree Protocol (RSTP), which enables virtual data circuits through the Ethernet network. Ethernet networks, regardless of redundant cabling, always select a single active path for message transit among devices on the network. Therefore, the switch and cabling design should be done by designers aware of the implications of underlying Ethernet path design technology to make sure the paths are appropriate for the applications that require data

exchange. Ethernet networks must be carefully engineered—not simply assembled.

Operational technology (OT) reliability is maximized by choosing IEDs with two Ethernet ports in failover mode connected to redundant switches. For power system OT, the most stringent applications require rapid and reliable message exchange among peers to perform teleprotection, interlocking, and high-speed automation. International standards for the reliability of teleprotection applications in power systems allow between 0 and 9 messages to be dropped in a 24-hour period of GOOSE exchanges, require that messages be delivered in less than 4 milliseconds 99.99 percent of the time, and require that the remaining 0.01 percent of exchanges experience a maximum transmit time of less than 10, 20, or 30 milliseconds, depending on the specific protection scheme [3]. Simply put, the message transit requirements are:

- Redundant message paths, in case the primary path fails.
- Low latency.

Designing for redundancy provides a secondary path after a segment or switch failure. Designing for low latency minimizes the number of switches the message must pass through while between devices.

Multicast messages within IEDs, such as IEC 61850 GOOSE messages, are sent to one or more IEDs to share data to accelerate teleprotection, interlocking, and high-speed automation. Best practices for configuring IEDs and switches for correct operation of GOOSE messages are discussed in Section VI, Subsection C. Virtual LAN (VLAN) segregation is important not only to manage the type and amount of traffic sent to each IED but also to manage the amount of traffic within the switches themselves. By keeping the traffic restricted to what is appropriate and necessary on each network segment, bandwidth saturation is less likely.

## VI. NETWORK ARCHITECTURE

### A. Network Topology

The LAN for Kintampo substation is designed to provide a reliable and deterministic platform for the substation communications-based protection schemes. The substation LAN is composed of a ring of substation-hardened industrial Ethernet switches. All of the IEDs have dual Ethernet ports operating in failover mode with two separate connections to two different switches. The IED connections are 100BASE-FX multimode fiber. A ring topology was chosen because, when combined with RSTP, this topology allows for network redundancy in the case of a connection or switch failure. Also, it is easy to understand, test, and install in the field. The IED count is sufficiently small, so that when connected in failover mode, this design matches or surpasses any other topology choice in regard to reliability and recovery. With this topology, no single failure in the network (or two or more failures in some cases) results in a loss of communication. Large rings experience long recovery times after a switch or link failure, so other topologies should be considered in different, larger systems. Fig. 11 displays a

portion of the Kintampo network layout. When designing switch-to-switch connections, it is recommended to use connections of similar or equal latency so they behave similarly and traffic behavior does not radically change when network reconfiguration moves traffic from one segment to its redundant partner. The latency of each segment is determined by its speed (i.e., the speed that it moves messages, described as capacity) or bandwidth.

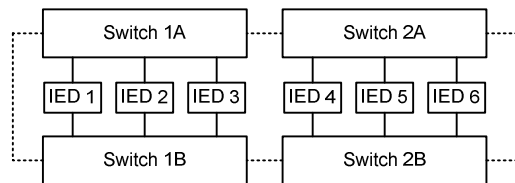

Fig. 11. Sample diagram of the network layout.

### B. Designing RSTP

Special care should be taken when designing a network that uses RSTP for recovery in the event of a failure. Taking the time to configure the various RSTP settings ensures that the network recovers in the most optimum way in the event of a failure. One of the switches in the network acts as the root bridge or root switch to be the starting point for all network topology decisions. Because there does need to be a starting point, if the user does not choose, the switches choose among themselves to select one, and only one, root. Left to choose on their own, switches use the media access control (MAC) addresses to decide. Network engineers should choose a root switch so they definitively know the topology and are able to predict topology changes. Root switch designation can be assigned to a device by setting the bridge priority to a sufficiently low number.

The RSTP process recognizes the root as the logical focal point of the network, and all segments are identified based on their proximity to the root. RSTP minimizes the distance that messages must travel from all points on the network to the root. Therefore, all IEDs close to the root are close to each other, with fewer cables and switches for the messages to pass through. If the network is a star or hub-and-spoke topology, then the switch at the center should be made the root bridge. At Kintampo, no switch is more physically central than the other because they are connected in a ring, so the switch with the most IEDs connected to it was selected as the root bridge.

### C. VLAN Design for GOOSE

The Ethernet switches at the Kintampo substation are configured with VLANs in order to segregate traffic on the network. Each IED network interface must process all Ethernet messages that it receives, including frequent IEC 61850 GOOSE messages, even if it is not the intended recipient. Because IEC 61850 GOOSE messages are multicast Ethernet traffic, Ethernet switches attempt to send them to every Ethernet interface in the system LAN. However, the Kintampo LAN switches are engineered to pass or deny the VLAN identifier (ID) of each GOOSE message based on which IED is connected to the switch ports. A unique VLAN was created for every IEC 61850 GOOSE message and the

switches set accordingly, so that the message is only delivered to the devices that are configured to receive it. By restricting the VLANs on each switch port to GOOSE messages that are configured to be received by the IED on a particular port, all of the other GOOSE traffic is blocked. This minimizes the amount of traffic that each IED must process and, as a result, maximizes the performance of the IED Ethernet ports. This also reduces the likelihood of bandwidth saturation on any network segment by reducing unnecessary traffic. Each IED port on the switch was configured with the same native-port VLAN ID or port-based VLAN ID for all of the other non-GOOSE traffic.

The complete list of best engineering practices for using Ethernet virtual wiring via digital messages to replace copper conductors is quite extensive [3]. Designers using protection, control, and monitoring (PCM) IEDs and networks for Layer 2 multicast messages must adhere to the following rules for designing and configuring messages and network engineering parameters:

- Assign each GOOSE message a unique VLAN based on IEEE 802.1Q, referred to as a QVLAN.
- Assign each GOOSE message a unique IEC 15802-1 multicast MAC address.
- Assign each GOOSE message a unique application identifier (app ID).
- Assign a descriptive GOOSE identifier (GOOSE ID) rather than a generic ID in the IED to improve documentation and troubleshooting.
- Label GOOSE message payload contents with descriptive rather than generic names in the IED to improve documentation and troubleshooting.
- Carefully design payload size and contents to facilitate appropriate GOOSE application processing—mind the gap.
- Carefully choose IEDs that process incoming GOOSE messages appropriately fast for protection-class applications—mind the gap.
- Do not publish multicast messages on the network without QVLAN tags.
- Disable all unused PCM communications ports.
- Monitor GOOSE message attributes to derive the quality of the message.
- Use the GOOSE attributes of sequence number and state number to determine if all wanted messages reach the receiver.
- Monitor, record, and alarm failed quality of GOOSE messages.
- Provide GOOSE reports with configuration, status information, and statistics pertaining to GOOSE messages being published and subscribed to by the IED.
- Record and alarm failed quality of GOOSE messages for use in local and remote applications.
- Display status of GOOSE subscriptions and alert operators of failure.
- Configure each switch port to block the ingress of unwanted messages and allow wanted multicast messages via VLAN and MAC filtering. This reduces the multicast traffic through the network to only that which is required.
- Configure each switch port to block the egress of unwanted messages and allow wanted multicast messages via VLAN and MAC filtering. This prevents unwanted messages from reaching the IEDs.
- Use switches designed for rugged environments and Layer 2 multicast among PCM IEDs in a fixed address network.
- Do not allow dynamic reconfiguration; this leads to unknown network configurations.
- Use switches that provide real-time status of traffic behavior and network configuration.

## VII. SUBSTATION AUTOMATION SYSTEM

### A. Substation Automation System Components

The substation automation system (SAS) at Kintampo includes an HMI to provide local indication and control of substation components and a remote terminal unit (RTU) to provide SCADA to the local HMI and the utility remote control center. The RTU performs data acquisition and control for the substation IEDs via the MMS communications protocol that is part of the IEC 61850 standard. The RTU provides remote SCADA via the IEC 60870-5-104 communications protocol. The Kintampo SAS has several unique features not common to a typical SAS, including hot-standby quadruple redundancy, highly customizable user access control, historical trending of metering data, and automatic event retrieval.

### B. Hot-Standby Redundancy

Most SAS designs separate the RTU and the HMI into two different hardware platforms for redundancy purposes in the event that one of them fails. At Kintampo, the RTU and the HMI are housed within the same software package and located on the same hardware platform, but the software has built-in hot-standby quadruple redundancy. There are four substation-hardened computing platforms in the Kintampo SAS that are configured exactly the same. The four software instances constantly communicate their status to one another via a heartbeat signal over Transmission Control Protocol/Internet Protocol (TCP/IP). At any given time, only one of the four computing platforms is actively performing data acquisition and control. When the active one has a hardware or communications failure, the next one automatically starts up and begins where the first left off. In order to preserve consistency and coherency of data across all four computing platforms, the same communication that provides the heartbeat signal also transmits any changes in data to the other three inactive computing platforms. The software automatically ensures that all four computing platforms have the same configuration and data.

### C. Access Control

The Kintampo substation is shared by two separate utilities: Ghana Grid Company Limited (GRIDCo) and Northern Electricity Distribution Company (NEDCo). GRIDCo operates the transmission portion of the substation, and NEDCo operates the distribution section. One of the user requirements is the ability to control access to the HMI with separate user accounts for each utility. The HMI and RTU software supports multiple users with unique credentials and access rights. The Kintampo substation has two control buildings, one for distribution and one for transmission, which require two separate touchscreen panels in either building. The touchscreen panel in the distribution control building is configured to automatically display the distribution portion of the HMI upon startup, and the touchscreen panel in the transmission control building is configured to automatically display the transmission portion of the HMI upon startup. When users log in to the HMI on either screen, they are asked to provide login credentials. Users of both utilities can view both sections of the HMI, but they are only able to perform operations on their section of the substation.

### D. Trending

The HMI and RTU software supports historical trending of metering data and is configured to sample and store various metering quantities, including power, current, and voltage. These sampled data are stored on the substation computer and saved for 30 days. The historical data sets are circular first in, first out (FIFO) files. The sampling interval and retention period determine the size of the files. The HMI is configured with customizable graphs to view and compare the data that are stored in the historical data sets. Users can open multiple graphs simultaneously and edit the time periods that are displayed on the graphs. The trending data can also be imported from the data set files into Microsoft® Excel® for further analysis using a Microsoft Excel plug-in. These trending capabilities are a useful tool when trying to forecast load requirements and provide users with greater insight into the historical behavior of the system.

### E. Automatic Event Retrieval

The SAS is equipped with software that performs automatic event record retrieval from substation IEDs. This software is housed on the same substation-hardened computing platform that contains the HMI and RTU. Protection event records are historical records of multiple data readings from multiple sensor measurements before, during, and after an event trigger, such as a fault on the power system. This software periodically connects via Telnet to all of the substation IEDs in a round-robin fashion at a user-configurable interval. The software archives event record files on the local storage of the substation computers and can also be configured to store event files on remote servers. Although

the station is staffed, this automatic event retrieval software allows operators to go to the SAS and collect all the event records to send to the engineering department. In the future, this information collection can be automated and done remotely via this software application.

## VIII. FACTORY ACCEPTANCE TEST

A factory acceptance test was conducted in an office environment to provide the end users with equipment familiarity, testing, and training in a safe environment. Due to the size of this project and the number of protection and integration panels, a complete factory acceptance test was not appropriate. However, a smaller scale of the substation was replicated with a complete transmission bay including the remote end along with a transformer panel and two 34 kV panels. The end users witnessed the full testing of this replicated system, allowing the engineers and end users to test the system and make final adjustments before overseas shipping.

Circuit breaker simulators were used to simulate closing and tripping of circuit breakers and MODs and thoroughly test and verify all logic and communications.

## IX. CONCLUSION

This paper discusses key aspects of the electrical design, protection and control, and communications network design at Kintampo. This paper demonstrates that the use of field kiosks does significantly lower the amount of wiring between the control house and the yard. Even interpanel wiring was greatly reduced by using IEC 61850 GOOSE messages for breaker failure initiate and tripping. The network design was chosen to provide network redundancy, reliability, and traffic control. The local HMI provides operators with local indication and control while providing remote access to SCADA operators.

As the acceptance of IEC 61850 communications by utilities grows, this type of large-scale project will grow as well. Just as with complete hard-wired projects, special engineering design must take place in the beginning stages of an IEC 61850 implementation project. In particular, the design of the network architecture is critical to make sure that the system can withstand single points of failure of network equipment and IEDs. Another challenge that remains is adequately training the operators who ultimately have to quickly respond to late-night emergencies. For example, the factory acceptance test has proven invaluable because it provided the engineers and operators training on the new technologies familiarity with the communications-assisted logic, LAN, and system performance and operation. A system solution that is repeatable, pre-engineered, pretested, and designed to specifications is extremely important because it provides the user with a standardized solution that can be implemented across the system, minimizing different designs.



## X. REFERENCES

- [1] T. Tibbals and D. Dolezilek, "Case Studies: Replacement of Copper Field Wiring With Interoperable Digital Communications Over Fiber," proceedings of the GCC Power Conference, Doha, Qatar, October 2010.
- [2] S. Kimura, A. Rotta, R. Abboud, R. Moraes, E. Zanirato, and J. Bahia, "Applying IEC 61850 to Real Life: Modernization Project for 30 Electrical Substations," proceedings of the 10th Annual Western Power Delivery Automation Conference, Spokane, WA, April 2008.
- [3] D. Dolezilek, N. Fischer, and R. Schloss, "Improvements in Synchronous Wide-Area Data Acquisition Design and Deployment for Telecontrol and Teleprotection," proceedings of the 14th Annual Western Power Delivery Automation Conference, Spokane, WA, March 2012.

## XI. BIOGRAPHIES

**Charles E. Anderson** is Vice President of Engineering for Meade Electric Company, Inc. He graduated with a BSEE from the University of Notre Dame in 1980 and holds master electrician licenses in seven states. Charles has experience in the design, construction, and commissioning of electrical power generation plants, high-voltage substations, and medium-voltage power distribution systems for both utility and industrial facilities.

**Salim Zniber** joined Schweitzer Engineering Laboratories, Inc. as a protection engineer in 2010. He has been involved in several projects for the engineering services division, which provides engineering services in protection, automation, and networking for utilities and industrial clients. Salim has worked on projects that include IEC 61850 and IEEE C37.118 engineering, design, and implementation. He holds a BSEE and MS in electrical engineering from the University of North Carolina in Charlotte.

**Youssef Botza** earned his BSEE from the University of North Carolina at Charlotte with honors and is currently employed as an engineering supervisor at Schweitzer Engineering Laboratories, Inc. He has several years of experience in power systems, providing protection and automation solutions and serving as a technical lead and project manager in the engineering services division. Youssef has been working on cutting-edge technology projects, specializing in IEC 61850 solutions. He is a registered professional engineer in the state of North Carolina and a member of the IEEE.

**David Dolezilek** received his BSEE from Montana State University and is a research and development technology director at Schweitzer Engineering Laboratories, Inc. He has experience in electric power protection, integration, automation, communication, control, SCADA, and EMS. He has authored numerous technical papers and continues to research innovative technology affecting the industry. David is a patented inventor and participates in numerous working groups and technical committees. He is a member of the IEEE, the IEEE Reliability Society, CIGRE working groups, and two International Electrotechnical Commission (IEC) technical committees tasked with the global standardization and security of communications networks and systems in substations.

**Justin McDevitt** joined Schweitzer Engineering Laboratories, Inc. as an associate automation engineer in 2010. He has been involved in several projects for the engineering services division, which provides SCADA and substation automation engineering systems and services for power system utilities and industrial clients. Justin is responsible for the development of automation, control and network systems, HMI design, communications processor settings, relay logic and communication, and commissioning. He has worked on several IEC 61850 substation automation projects with complex automation and protection communications schemes. He has a BS in computer engineering from the Georgia Institute of Technology.