

# Case Study: Revised Engineering and Testing Practices Resulting From Migration to IEC 61850

Harold Fischer, Jeffrey Gilbert, and Greg Morton, *PPL Electric Utilities Corporation*  
Michael Boughman and David Dolezilek, *Schweitzer Engineering Laboratories, Inc.*

**Abstract**—Replacing hardwired connections with digital communications over Ethernet requires new engineering and testing practices. PPL Electric Utilities Corporation (PPL) recently designed, installed, and tested a new high-voltage substation using next-generation relay and control equipment. This next-generation substation (NGS) is based on networked Ethernet intelligent electronic devices (IEDs) communicating via IEC 61850. This paper discusses the new technical design details of networking IEDs over Ethernet, but also, and more importantly, it discusses how engineering, installation, and testing practices had to change to accommodate the new technology. PPL methodically replaced their previous protection and control design with a design that provides more functionality while migrating to IEC 61850 communications from multiple IED vendors.

In the end, over 50 percent of the hardware, 60 percent of the hardwired connections, many disparate programmable devices, and several software programs were eliminated. New testing techniques were developed to test IEC 61850 communications, and wiring drawings were replaced with GOOSE messaging tables so that test technicians could identify the endpoints of the “virtual” wires.

The NGS implementation required completely new communication design methods, IED configuration, verification testing, and system commissioning. This paper describes PPL’s process of developing best engineering practices for substation protection, integration, control, monitoring, metering, and testing. A discussion of these engineering practices and how they evolved provides valuable insight to engineers considering using one or more of the IEC 61850 protocols for peer-to-peer protection and automation or client/server methods for integration and automation.

Lessons learned were associated not only with new technology but also with new procedures, such as how test technicians selectively block signals that communicate over Ethernet without physically disconnecting the IED from the network. The paper also discusses PPL’s creation of a project team consisting of representatives from engineering, operations, standards, and relay testing to collectively resolve concerns associated with system testing, future expansion, and maintenance of this design.

## I. INTRODUCTION

Previous PPL substation integration and automation systems utilized redundant programmable logic controllers (PLCs) as the substation data concentrator. Using discrete input/output (I/O) interface modules, interposing relays, and serial communications to IEDs via direct connection, substation information was collected by the “Substation” PLCs. The “Substation” PLCs would then pass this

information to the SCADA RTU before the information was sent to the SCADA master.

Rather than propagate the existing PLC-based design, PPL engineers developed an alternative that incorporated the existing IEDs and improved the integration and automation, while also simplifying the system architecture. The new design relies on several protocols within IEC 61850 to support peer-to-peer relay communications, human-machine interface (HMI), and SCADA connections. Fully utilizing the available I/O in the relays and other IEDs essentially replaces large amounts of copper contact and transducer wiring with a few communications cables. The result eliminates equipment and reduces configuration, installation, commissioning, and maintenance costs.

However, this presents a new challenge. Although the new data acquisition methods promise to reduce the overall amount of labor, they also dramatically change the technology used for system configuration, installation, commissioning, and maintenance. These new technologies require new processes to provide an understanding of unseen data flow inside the communications network and a certainty that the protection and control systems will operate properly.

## II. PREVIOUS COMMUNICATIONS DESIGN OVERVIEW

Prior to the new design, substations were designed with an integration architecture that included a combination of PLCs, direct-wired I/O modules, transducers, microprocessor-based relays, and other IEDs. A master “Substation” PLC passes remote controls issued from the SCADA master onto the “Bay” PLCs. The “Bay” PLCs pass on the SCADA commands to the protective relays, which, in turn, operate the substation apparatus. The “Bay” PLCs collect breaker status, alarms, and other digital inputs. Metering quantities were collected from separate transducers, and relay target statuses were collected directly from the multiple connected relays. The “Substation” PLC concentrates the data from the “Bay” PLCs into a single database and passes data to the SCADA master using a single serial Modbus<sup>®</sup> protocol connection.

Because the PLC-centric design required extensive I/O wiring, interposing relays, additional protocol modules, and configuration expertise, PPL engineers initiated a program to investigate alternatives.

PPL eventually developed the following design criteria for their new substation IED network architecture:

- Eliminate the PLC, and reduce the number of programmable devices.
- Reduce I/O wiring.
- Utilize data within existing protective relays.
- Use communications wherever possible to collect SCADA data.
- Apply protective relays to implement local automation.
- Implement new fiber-optic network communications systems for HMI, SCADA, and engineering access.
- Provide integrated network communications compatible with the existing online SCADA master.
- Ensure that the integration and automation system is compatible with the two different relay vendors.
- Eliminate the stand-alone sequential events recorder (SER) device and metering transducers.

### III. BUSINESS CASE OVERVIEW

PPL found that they were able to achieve a number of subjective benefits by applying the new design. Specifically, the application of programmable “smart” digital relays and interoperable communications protocols provided the following benefits:

- Smart relays may be programmed to perform both control and protection functions, eliminating the need to install and maintain several devices.
- The use of industry-standard protocols, such as IEC 61850 and DNP, facilitates communication between relays and other manufacturers’ devices and permits the application of the most cost-effective hardware.
- The same hardware design can be applied to various substation arrangements and voltage classes, reducing time for engineering and testing.
- The utility has the option of developing software and performing system integration either in house (to acquire and maintain expertise) or through contractors (when in-house engineering resources are committed to other projects).
- Panel space requirements are minimized because there are fewer “boxes” to mount on panels.
- Wiring from circuit breakers to panel terminals may be kept the same as the previous generation design. Future designs can replace the wiring between the device and panel terminals with digital communications paths without impacting the new network IED design.
- From a physical viewpoint, relay replacement requires the rearrangement of only a small number of external wiring connections. Programming and settings changes may also be required.

- Substation engineers are generally more comfortable developing relay software than computer software because they are accustomed to working with relays.
- The NGS design is less complex than the prior PLC-based design.

These benefits directly impact the system’s installation and life-cycle costs. Costs for the in-service station, using this new design, are not available for publication. However, a recent study compared system installation costs for the protection and control of a three-breaker, ring-bus switchyard based on the previous PLC-centric design and the new NGS relay network design. These results are summarized in Table I.

TABLE I  
THREE-BREAKER, RING-BUS SWITCHYARD  
INSTALLATION COST COMPARISON

Three-Breaker Ring Description	Cost Difference Between First New NGS Design Installation and Previous PLC-Centric Standard
Hardware	-\$33,000
Software	+\$70,200
Installation	-\$33,000
Testing	-\$11,000
Development	+\$138,000
Training	+\$36,000
Engineering	-\$6,800
Drafting	-\$11,500
Documentation	+\$60,000
<b>Total Costs (First Installation)</b>	<b>+\$158,000</b>
<b>Total Costs (Future Installations)</b>	<b>-\$144,000</b>

The installation cost for the first three-breaker, ring-bus-type substation design using the NGS design is greater than the cost of the previous PLC design. This is due to higher costs of the following:

- Training engineers, test technicians, and system operators.
- Developing standards, software, and test procedures.
- Documenting hardware and software.

These increased costs are partially offset by savings in the following areas:

- Hardware costs are lower because many of the devices needed in the previous design are no longer required. These functions are now performed in the relay.
- Installation and wiring costs are lower because there are fewer wire connections.
- Testing costs at the site are lower because there are fewer hardware devices and associated connections.
- Engineering and drafting costs are also reduced for the same reasons.

The cost of installing the new NGS design for subsequent projects is significantly lower than the cost of using the PLC-centric design. Engineering, drafting, software, and development costs are expected to be significantly lower than for the

initial project, and most of the nonrecurring work is already complete.

#### IV. IMPLEMENTING NEW TECHNOLOGY WHILE MAINTAINING EXISTING WORK METHODS

##### A. HMI Development

Existing standards within PPL utilize an in-house developed HMI system. The HMI interfaces with “Substation” PLCs via Modbus Plus® to populate and animate the customized views. In order to ensure that the operators and engineers would adopt the existing HMI screens, a great amount of teamwork went into the process. This made it imperative that the new NGS HMI maintained the same look and feel as the previous PLC-based HMI, while manufacturing messaging service (MMS) became the data-update mechanism in the NGS. The new HMI development was planned so that it could be utilized at existing, new, or future substation designs, regardless of the protocols or mixture of protocols on the network.

In the end, PPL was successful in reusing much of the previous HMI development. A new HMI OPC (object linking and embedding for process control) interface was created so that existing HMI template views could be preserved and reused. Rather than associating the HMI value fields with a member of an incoming protocol map, OPC tags were used. OPC is essentially the method by which protocol software and HMI software communicate to one another within the PC. Any software that interfaces with OPC, such as Modbus, DNP, or IEC 61850 MMS protocol applications, can now update HMI tags. Now, this HMI design will support any of the protocols PPL chooses to use in the future. The OPC interface to the HMI supports the use of multiple protocols simultaneously as well.

The PPL HMI system was developed in house using Microsoft® Visual Basic® and tools from an OPC automation interface. The program was built around modular Microsoft ActiveX® controls designed for each device. This provided PPL a great amount of flexibility to create customized applications for any substation configuration. The HMI one-line screen shows the device status, power system quantities, and reclosing preferences for the entire substation. Clicking on or near a device will load the control screen for that device, which displays a detailed view of the selected devices, along with their status and analog values. This screen also presents the user with controls for the selected device. At any point, the user can return to the one-line screen using on-screen navigation buttons. An example of an HMI one-line diagram screen capture is illustrated in Fig. 1.

##### B. Communications Commissioning and Checkout

As in the past, a sufficient methodical system checkout was performed during commissioning to verify proper data flow, and the results of the testing and verification were documented and archived for future review. PPL slightly modified their procedures to accommodate IEC 61850 MMS and GOOSE but continue to document and archive the results of communications checkout. These archives serve to provide future review of the test results and a starting point to perform additional testing. PPL found that when they added new functionality to an existing system, they needed only perform iterative partial testing. Using the thoroughly documented results of the previous system checkout, PPL engineers can confidently test new changes and only the parts of the network that the changes impact. Most importantly, because of their documentation procedures, PPL engineers know what needs to be tested as a result of these changes.

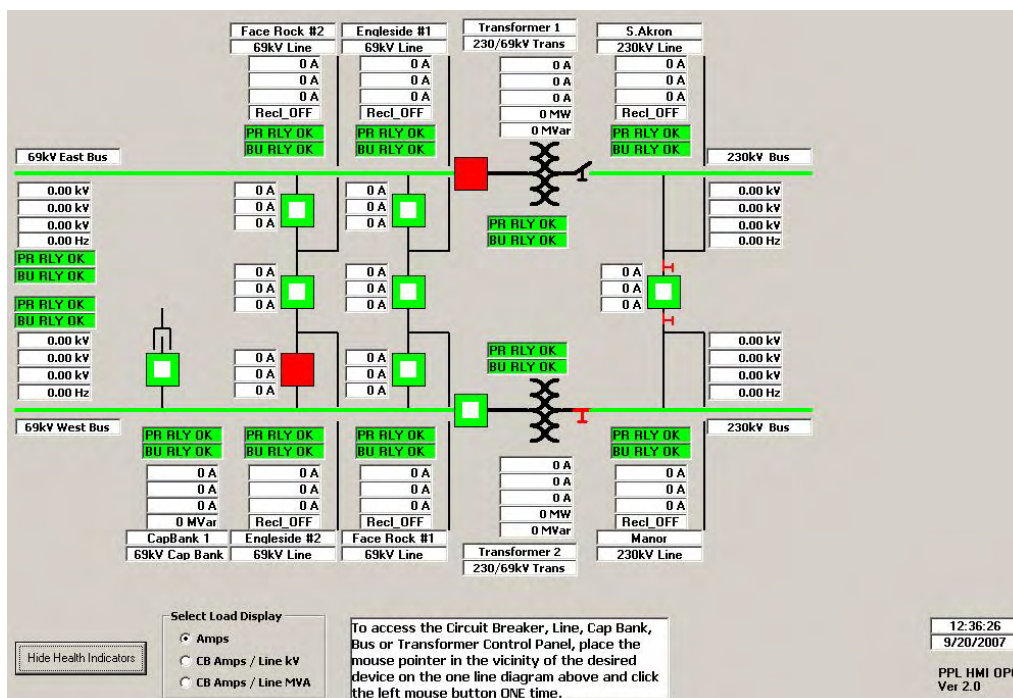

Fig. 1. Station HMI One-Line Diagram Screen Capture

## V. CHANGES TO METHODOLOGY

One major difference that affects all parts of commissioning and testing is that the new PPL NGS design uses a single Ethernet port on each IED. The second is that all PLCs are eliminated, and the upper-tier PLC is replaced with a communications processor.

### A. Use More Microprocessor IED Multifunction Capabilities

Prior to the NGS design, the PPL design was mostly hardwired, with the exception of some PLC communications. The design incorporated three communications networks. Redundant Modbus TCP networks for Bay PLC/Substation PLC communications and one Modbus Plus network for SCADA and metering communications were implemented.

Existing PLC-based designs were used as a starting point when embarking on the NGS design. Using functions already built into the microprocessor-based relay eliminated hardware and associated panel wiring. For example, the “Bay” PLC and fault detector were eliminated by moving breaker failure and direct transfer trip (DTT) logic functions into the relay. Digital transducers were also removed because the necessary data was already available in the microprocessor-based relays. Because the analog data were now available on the Ethernet port, PPL planned to use relay data to support the SCADA system, without the need for additional transducers. Previous substation designs used microprocessor-based relays for protection only. Other functions, such as fault detection, SER, etc., were performed by dedicated devices. The flexibility and reliability of microprocessor-based relays allowed the elimination of dedicated devices from the NGS design, because these functions now reside in the relay.

### B. Replacing Wired Terminations With Digital Communications

Protective relays now perform many functions besides protection. The advantages that modern microprocessor-based relays provide over traditional relays are well documented. These advantages include fault location, event reports, and programmable logic that allow many functions to be included in one device, thus saving hardware and wiring costs. One important complication of the technology shift is the increasing portion of the protection system design that resides in algorithms and logic in relays [1]. With the elimination of devices and hardwired connections, new methods of testing and documentation had to be developed. Previous substation designs utilized wiring diagrams or drawings for point verification. Points previously hardwired are now broadcast onto an Ethernet network via IEC 61850 GOOSE messages. Table II provides a partial example of the peer-to-peer network communications design documentation. This information replaces point-to-point wire connections. It is used to facilitate testing and system troubleshooting.

### C. Communications Messaging Isolation for Test

Challenges must be expected when a new design is developed. The NGS challenges were not always technical; some were procedural. For instance, how do test technicians selectively block signals communicating over Ethernet. To

address these and other important issues, a project team consisting of representatives from engineering, operations, standards, and electrical testing was formed. Issues were discussed at length, and the system was designed to accommodate concerns associated with testing, scaling and expanding, and maintaining the design. For example, with previous substation designs, the need to block a particular function was imposed by opening a physical switch in the relay contact wiring circuit. The NGS utilizes a logic qualifier in the relay to block or enable GOOSE message broadcasts.

Because all IED communications are now interleaved through a single Ethernet port, PPL devised a way to isolate individual communications paths. When an operator chooses to block a GOOSE message, the contents are not actually updated. Although the IED GOOSE messages continue to be published, the payload, or data set, will not be updated with new values when the message is blocked. The HMI test display was modified to include a control to enable and disable the GOOSE data set update. When the operator chooses to disable GOOSE updates, a logic bit is set in the HMI and sent to the IED. The IED constantly checks this logic and its status with the update process. Using this method, individual bits or entire data set contents can be blocked from being updated in outgoing IED GOOSE publications.

TABLE II  
PARTIAL EXAMPLE OF PEER-TO-PEER NETWORK COMMUNICATIONS  
DESIGN DOCUMENTATION

Transmit Data Sets	Receive Data Sets				
	Primary Bay 1 Line 1 Relay				
	1	2	3	4	5
Backup Bay 1 Line 1 Relay	1	X			
	2				
Primary Bay 1 Line 2 Relay	1		X		
	2				
Backup Bay 1 Line 2 Relay	1			X	
	2				
Primary Bus Section 1 Relay	1				X
	2				
Backup Bus Section 1 Relay	1				X
	2				
Bay Line Transmit Data Set 1	Bay Line Transmit Data Set 2				
CB 1 Manual Trip/Close	Normal Bus Test Source				
CB 1 Relay Trip	Alternate Bus Test Source				
CB 2 Relay Trip					
CB 1 Auto Reclose Enable					
CB 2 Auto Reclose Enable					
CB 1 Out of Service					
CB 2 Out of Service					

#### D. Communications Messaging Changes for HMI Update

With the elimination of PLCs and single-function devices, the substation network had evolved. The Modbus Plus network was replaced by an Ethernet network, supporting multiple SCADA, peer-to-peer, and engineering access protocols. New software and programming tools were needed to configure the new system. Vendor-available software tools were used to develop relay logic, HMI programming, field simulation, testing, and documentation.

As stated before, the changes to the HMI were kept to a minimum. The previous HMI communicated to redundant PLCs to collect data. The NGS network now provides the HMI the ability to communicate with each relay. The HMI database update mechanism was changed from master/slave to client/server. This was done by simply changing the application that updated the HMI database from a SCADA protocol to IEC 61850 MMS. Using MMS, the database is now updated using client/server.

With the ability to communicate with each relay came the need for comparative logic in the HMI. When multiple relays provide data for one apparatus, such as a tie breaker, the HMI compares the data from all sources and flags any discrepancies. The HMI provides the operator with the ability to view all data sources via a health-indicator button and determine which relay is not in agreement. This function is illustrated in

Fig. 2. The operator also has the capability to remove the questionable IED from the scan.

The health and status of the relays are constantly monitored within the HMI to ensure accurate data are presented to the user. Because the protection design includes redundant relaying, any data disruption from a primary relay will cause the HMI to shift to the backup device for any analog data. Status data display is handled a bit differently. In order to ensure the relays remain consistent, the status of all the devices is combined using a Boolean AND statement. Any discrepancies between status values in the relays will be indicated with a yellow flag on the affected device(s). The HMI one-line and device control screens indicate abnormal health or status with a red or yellow alert icon for each affected relay. The HMI also allows the user the option to force any relay out of service and disregard any data coming from that device. This is useful when removing a relay from service to perform testing or maintenance without affecting the HMI status and analog quantities.

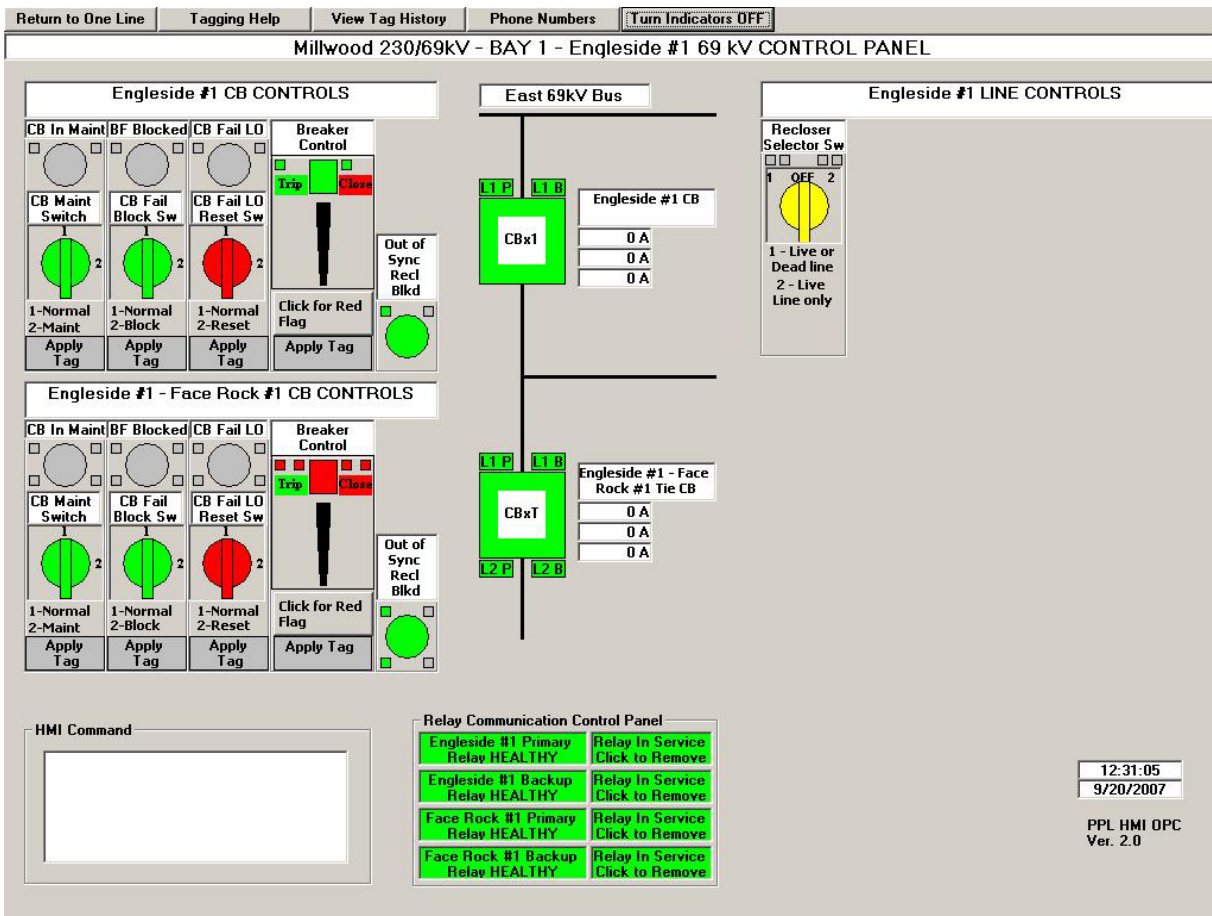

Fig. 2. HMI Display Illustrating Values From the IEDs and the IED Health

### E. Point Verification

PPL developed an HMI view that provides GOOSE monitoring to aid in verification of peer-to-peer digital communications interconnections. The application creates and displays GOOSE diagnostics as well as the data set contents from each IED. The application supports control of the GOOSE message behavior from the IEDs. Like the hardware tests before, GOOSE test methods support iterative tests during commissioning as well as future changes and additions. The test results are saved, and screen captures of the GOOSE monitor application are saved as test process artifacts. Fig. 3 illustrates an example screen capture of the GOOSE message tables used by technicians to identify “virtual connections” among IEDs.

The GOOSE system is designed around standard transmit data sets that serve two distinct purposes. The intent of the first transmit data set is to exchange protection data and ensure consistency between the redundant relaying data. Other transmit data sets serve the exchange of nonredundant relaying data or scheme data, such as bus differential tripping. A wired contact input on each relay permits blocking of all GOOSE data set transmissions by simply opening a test switch during relay testing or maintenance.

The GOOSE data set application IDs and the transmitting relay IP address easily identify the data source. All of the transmit data sets are multicast across the substation network. Each relay is configured to subscribe to only the data sets it needs, and then the required data points are mapped into the relay logic.

The redundant relaying transmit data sets contain status data, such as maintenance switch status, breaker failure blocking switch status, line reclosing preference, bus test sources, and relay health. Protection data, such as breaker failure initiate, breaker failure lockouts, and transformer lockouts, were also included in this data set. The other transmit data sets contained data for bus differential tripping, breaker failure on a bus breaker, and bus testing after an operation.

GOOSE analog data are planned for use in future synchronism check and bus testing schemes but have not been implemented in current designs.

## VI. NETWORKED IEDS IMPROVE SYSTEM CAPABILITIES

The act of integration realizes significant system benefits over traditional methods of measuring multiple field terminations, regardless of the protocol(s) or communications media used [2].

The screenshot shows the 'Millwood 230/69kV - GOOSE MONITOR' interface. It features a menu bar with 'File', 'Monitor One Line', 'Bus Load Calculator', and 'Phone Numbers'. The main area is divided into several sections:

- Top Section:** Four dropdown menus for 'LS BAY 1 LINE P', 'LS BAY 1 LINE 1 B', 'LS BAY 1 LINE 2 P', and 'LS BAY 1 LINE 2 B'. To the right are two 'Choose Relay Type' dropdowns.
- Second Section:** Four dropdown menus for 'TRANSMIT DATA SET 1' through 'TRANSMIT DATA SET 3' and 'RECEIVE DATA SET 1' through 'RECEIVE DATA SET 3'. To the right are two 'Choose Data Set' dropdowns.
- Third Section:** Six panels, each titled 'Active TX/RX'. Each panel contains a list of data points with status indicators (red and green squares). The data points include:
  - Panel 1: BkX MAN T/CL, Bk1 RLY TRIP, BkT RLY TRIP, Bk1 AutoCLS, BkT AutoCLS, BkT MANT Sw, BkT MANT Sw, Bk1 BFCO Sw, BkT BFCO Sw, Bk1 BFLO, BkT BFLO, Bk1 NAC, BkT NAC, LODL, LLO, RLY HLTH.
  - Panel 2: BkX MAN, Bk1 RLY TRIP, BkT RLY TRIP, Bk1 AutoCLS, BkT AutoCLS, BkT MANT Sw, BkT MANT Sw, Bk1 BFCO Sw, BkT BFCO Sw, Bk1 BFLO, BkT BFLO, Bk1 NAC, BkT NAC, LOD, LLO, OPP RLY HLTH.
  - Panel 3: BkX MAN, Bk1 RLY TRIP, BkT RLY TRIP, Bk1 AutoCLS, BkT AutoCLS, BkT MANT Sw, BkT MANT Sw, Bk1 BFCO Sw, BkT BFCO Sw, Bk1 BFLO, BkT BFLO, BkT NAC, BkT NAC, LOD, LLO, OPP RLY HLTH.
  - Panel 4: BkX MAN T/CL, Bk1 RLY TRIP, BkT RLY TRIP, Bk1 AutoCLS, BkT AutoCLS, BkT MANT Sw, BkT MANT Sw, Bk1 BFCO Sw, BkT BFCO Sw, Bk1 BFLO, BkT BFLO, Bk1 NAC, BkT NAC, LOD, LLO, OPP RLY HLTH.
  - Panel 5: Label0 through Label15.
  - Panel 6: Label0 through Label15.
- Fourth Section:** Four dropdown menus for 'LS BAY 1 LINE 1 P', 'LS BUS SECTION 1 P', and two 'Choose Relay' dropdowns. Below are two 'TRANSMIT DATA SET 2' and 'RECEIVE DATA SET 2' dropdowns, and two 'Choose Data Set' dropdowns.
- Fifth Section:** Six panels, each titled 'Active TX/RX'. Each panel contains a list of data points with status indicators (red and green squares). The data points include:
  - Panel 1: NorBusTst OK, AllBusTst OK.
  - Panel 2: NorBusTst, AllBusTst.
  - Panel 3: Label0 through Label15.
  - Panel 4: Label0 through Label15.
  - Panel 5: Label0 through Label15.
  - Panel 6: Label0 through Label15.

Fig. 3. GOOSE Message Table Example

Systems constructed with integrated IEDs networked via wireless, copper, fiber, serial, or Ethernet connections combined into a local-area network (LAN) offer the following benefits:

1. Due to the reuse of data detected by a single IED and digitally communicated to integrated IEDs and other data clients, field terminations, associated wiring, labor, and maintenance are reduced.
2. By using IEDs that, in addition to their primary functions, also perform ongoing diagnostics of their own performance and that of the equipment they are monitoring, the quantity of unsupervised process and apparatus functions is reduced.
3. Confirming the availability and reliability of the method by which the data are being collected and alarming when the data path is broken, the minimized distance of the unsupervised data path between the field source and data client(s) greatly improves the value of the data. Supervision is maximized by replacing traditional, unmonitored copper terminations with monitored digital communications at the IED closest to the field data. This, in turn, detects and alarms communications problems immediately.
4. Using methods that interleave multiple communications paths onto a single serial or Ethernet connection reduces the quantity of communications connections.
5. Because newer multifunction IEDs replace multiple, individual-purpose IEDs and because integration of IED data eliminates several traditional stand-alone systems, including those that perform SCADA, metering, SER, and digital fault recording, IED quantities are reduced.
6. Increased process and apparatus monitoring and control capabilities via the exchange and aggregation of data among many IED data sources rather than using a traditional implementation of only one IED and one data source per function. This ability to freely allocate data sources among IEDs networked using serial or Ethernet networks minimizes the importance regarding which IED is the data source and leads to more functional, flexible, and data-rich systems.

Any protocol standard used to network IEDs is capable of providing some of the benefits listed above. These protocols include DNP, Modbus, and IEC 60870. However, standards that include protocol suites to satisfy the aggregate of peer-to-peer, client/server, device configuration, and engineering access communications methods, such as the well-known relay vendor's interleaved protocols and IEC 61850, will provide the most benefit. These benefits are available whether the protocol suites are proprietary or nonproprietary; however, nonproprietary methods, in this case, led to better interoperability among the different vendor IEDs. Due to the application-specific requirements, however, it was necessary to support multiple methods of communications simultaneously to match different performance requirements. As an example, command line prompt via Telnet and file transfer via FTP are two different examples of standardized engineering access over Ethernet.

## VII. ESSENTIAL IED-LEVEL TOOLS

Multifunction, microprocessor-based relays incorporate not only multiple relay functions in one "box" but also include programmable logic capabilities. These logic capabilities allow various "logic schemes" previously implemented by wiring auxiliary relays, timers, and devices together to be implemented in a single device using settings [3]. The technician and/or engineer tasked with testing or troubleshooting an installation can visualize the logical function as an electrical path on the diagram. However, verifying that messages and the data that they transfer are correctly moving over the Ether requires new, specialized tools.

### A. GOOSE Message Statistics

In order to make GOOSE messages perform adequately, many traditional Ethernet mechanisms had to be removed and, in fact, a new and unique Ethertype had to be created. Each GOOSE message must fit within a single Ethernet frame, so each consecutive message has a unique sequence number incremented by one. The subscribing IED can determine if GOOSE messages are received out of sequence. Each time the message contents change, the message status number is incremented. This allows the subscribing IED to determine which message it has received and determine if the message payload has changed.

### B. GOOSE Message Quality Calculation

There are several characteristics that need to be monitored to verify the correct publication and subscription of GOOSE messages. The receiving IED needs to verify both the quality of the messages as well as the quality of the data within the message. Communications diagnostics rely on message quality. Each IED should verify the message quality by combining the status of each of the following codes (Table II). If any of these are set, the message quality indicates failure.

TABLE II  
GOOSE MESSAGE ERROR CODES

Message Statistics	Error Code
Configuration revision mismatch between publisher and subscriber	CONF REV MISMA
Publisher indicates that it needs commissioning	NEED COMMISSIO
Publisher is in test center	TEST MODE
Received message is decoding and reveals error	MSG CORRUPTED
Message received out of sequence	OUT OF SEQUENC
Message time to live expired	TTL EXPIRED

### C. GOOSE Diagnostic Message

Using the Telnet engineering access port, the GOOSE diagnostics are retrieved to show the configuration and status of incoming and outgoing GOOSE messages. The message shown in Fig. 4 displays the outgoing GOOSE message configuration and performance. Configuration information for

each GOOSE message includes a message label, multicast address, priority tag, virtual LAN identifier, and data set name. Real-time statistics for each message include the status number, sequence number, time to live, and error code. If detected, an error code from Table II is displayed.

```

SEL_451CFG/LLN0$G0$GooseDSet13
Data Set: SEL_451CFG/LLN0$DSet13

GOOSE Receive Status
-----
MultiCastAddr  Ptag:Vlan  StNum  SqNum  TTL  Code
-----
SEL_421CFG/LLN0$G0$GooseDSet13
01-0C-CD-01-00-10 4:2 1750 53262 0 TTL EXPIRED
Data Set: SEL_421CFG/LLN0$DSet13

#>>G00

GOOSE Transmit Status
-----
MultiCastAddr  Ptag:Vlan  StNum  SqNum  TTL  Code
-----
SEL_451CFG/LLN0$G0$GooseDSet13
01-0C-CD-01-00-11 4:2 204 63817 953
Data Set: SEL_451CFG/LLN0$DSet13

GOOSE Receive Status
-----
MultiCastAddr  Ptag:Vlan  StNum  SqNum  TTL  Code
-----
SEL_421CFG/LLN0$G0$GooseDSet13
01-0C-CD-01-00-10 4:2 1750 53397 1998
Data Set: SEL_421CFG/LLN0$DSet13

#>>

```

Fig. 4. GOOSE Diagnostic Statistics Retrieved via Telnet-Over-Ethernet LAN

#### D. GOOSE Message Failure Alarm and Notification

The subscribing IED calculates GOOSE message quality for each incoming GOOSE message. Because these methods are standardized, each IED is capable of calculating the GOOSE message quality for GOOSE messages from any vendor IED.

Once the IED has calculated the GOOSE message quality status, this value is available as a logic element within the IED. Each IED uses this status to block and enable logic, display GOOSE status on the IED front panel to aid troubleshooting, and alarm technicians via SCADA protocols or email, short message service (SMS), or telephone messages. The change of status state is also timestamped and recorded as an SER.

#### E. GOOSE Message Reliability and Channel Availability

Once recorded as a timestamped SER, the GOOSE message quality status for each message is collected as a system-wide diagnostic. After commissioning, message quality will only fail when a message is corrupted or not received. The observation of failures will indicate the reliability of individual GOOSE messages. If the message quality failure is intermittent, the duration of the failures is calculated as the difference between timestamps. The aggregate of failure duration over a given amount of time determines the channel availability.

#### F. Verification of Peer-to-Peer Virtual Channels

Ethernet networks usually support multiple paths over the Ether between different points on the network. Routing and diagnostic methods support the verification of successful transmission between two points on the network, but not the path taken. The common standardized “ping” diagnostic executed by a client (e.g., an engineering workstation or

SCADA/HMI computer) determines if it can contact the specified server over the network. The server in question, for example an IED, is identified by its network address. If successful, the ping application verifies that the client and server can make contact over the network. This implies that peer-to-peer applications using these two network addresses will also be successful. In order to verify connections to the entire network, the client pings all of the IEDs or other servers.

Although useful, this client/server ping verification back to a computer does not confirm that IEDs can contact each other over the network. Therefore, IEDs must ping each other to verify the peer-to-peer channel. Pinging between two IEDs is shown in Fig. 5, where the appropriate access level is protected by network security and IED passwords. In this example, a serial HyperTerminal session is used to interact with the IED Ethernet interface and cause it to ping the IED with address 10.201.0.242.

```

TIRECV := "V"
TIPNUM
TZCBAN := "

=>por 5
Transparent session to port 5 established.
#acc

#>2ac

#>>ping 10.201.0.242
Pinging 10.201.0.242 (Ping = 64 bytes)
Hit Enter to Terminate Ping Test.

Ping Echo Message Received.
Ping Echo Message Received.
Ping Echo Message Received.
Ping Echo Message Received.
Ping Echo Message Received.
Ping Echo Message Received.
Ping Echo Message Received.
Ping Echo Message Received.
Ping Echo Message Received.
Ping Echo Message Received.
Ping Echo Message Received.
Ping Echo Message Received.

Ping Results:
Number of ping messages:
Transmitted: 11
Received: 11 -- Duplicated 0

#>>_

```

Fig. 5. HyperTerminal Display of One IED “Pinging” a Second Peer IED

## VIII. CONCLUSION

Using new IEC 61850 client/server methods to replace traditional master/slave methods were accomplished without making major changes to the previously designed HMI and SCADA interfaces.

PLCs were easily replaced with an IED network and communications processor by using more functionality available in the IEDs. Software tools were developed by PPL to accommodate new engineering and testing practices. During the software design process, special considerations were made with regard to system expansion, troubleshooting, and maintenance of the system. It was important to PPL that the system was easy to expand, test, and maintain.

Messaging interoperability between peers depends on the device properties and the system architecture. Commissioning tests must be performed to verify that the communications behavior of a device as a system component is compatible with the overall network design. Stand-alone network test devices, HMI applications designed to observe network



messaging, and internal IED diagnostics are all essential to configure, verify, and troubleshoot network communications.

## IX. REFERENCES

- [1] Karl Zimmerman, "Commissioning of Protective Relay Systems," presented at the 34<sup>th</sup> Annual Western Protective Relay Conference, Spokane, WA, October 2007.  
Available at [www.selinc.com/techpprs.htm](http://www.selinc.com/techpprs.htm).
- [2] Eric Udren and David Dolezilek, "IEC 61850: Role of Conformance Testing in Successful Integration," presented at the 8<sup>th</sup> Annual Western Power Delivery Automation Conference, Spokane, WA, March 2006.  
Available at [www.selinc.com/techpprs.htm](http://www.selinc.com/techpprs.htm).
- [3] Jason Young and Derrick Haas, "The Importance of Relay and Programmable Logic Documentation," presented at the 2008 DistribuTECH Conference and Exhibition, Tampa, FL, January 2008.

## X. BIOGRAPHIES

**Harold Fischer** earned his BSEE from Lafayette College and is currently the relay test manager at PPL Electric Utilities Corporation. Since he joined PPL in 2000, he has been responsible for the design, installation, commissioning, and testing of protection, control, and substation communication equipment. He served as the project technical lead for the next generation substation design. His previous work experience included the design of power distribution and lighting systems for power plant and petrochemical facilities. He is a registered Professional Engineer in the Commonwealth of Pennsylvania.

**Jeffrey Gilbert** received his BSEE degree from Lafayette College and his MSEE degree from Lehigh University. He has been employed in engineering positions by PPL Electric Utilities Corporation since 1972, where he currently is a senior staff engineer in substation engineering. His experience includes participation on teams that developed two generations of programmable logic controller based protection and control systems and the smart relay design. Jeff is a senior member of IEEE and serves as standards coordinator for the Power Engineering Society Power System Relaying Committee. He is a registered Professional Engineer in the Commonwealth of Pennsylvania.

**Greg Morton** earned his BSEE degree from Rensselaer Polytechnic Institute. He joined PPL Electric Utilities Corporation in 2005, where he is currently a relay test support engineer. His experience includes the testing and maintenance of protection, control, and communications equipment. He participated on several project teams to develop the next generation substation design. He also implemented a relay maintenance and inventory management system. He attained his EIT certification in the Commonwealth of Pennsylvania.

**David Dolezilek** received his BSEE from Montana State University and is the technology director of Schweitzer Engineering Laboratories, Inc. He has experience in electric power protection, integration, automation, communications, control, SCADA, and EMS. He has authored numerous technical papers and continues to research innovative technology affecting our industry. David is a patented inventor and participates in numerous working groups and technical committees. He is a member of the IEEE, the IEEE Reliability Society, CIGRE working groups, and two International Electrotechnical Commission (IEC) technical committees tasked with global standardization and security of communications networks and systems in substations.

**Michael Boughman** earned his BSEE from the University of North Carolina at Charlotte. He has over 20 years experience in substation integration and automation design and implementation. In 1999, he joined Schweitzer Engineering Laboratories, Inc. (SEL) as an integration application engineer. His responsibilities include technical support, application assistance, and training for SEL customers. Michael is a registered Professional Engineer in the State of North Carolina.