

# Testing and Troubleshooting IEC 61850 GOOSE-Based Control and Protection Schemes

Edsel Atienza, *Schweitzer Engineering Laboratories, Inc.*

**Abstract**—IEC 61850 GOOSE (Generic Object-Oriented Substation Event) provides many advantages, including flexibility and reduced wiring, but introduces new challenges. Traditional tools and techniques cannot check the status of contacts and coils between intelligent electronic devices (IEDs) in a GOOSE-based scheme. Data on Ethernet networks are generally not documented in traditional substation wiring or elementary diagrams. The previous generations of relay test sets are not equipped to monitor GOOSE messages from relays.

As hard-wired schemes are converted to GOOSE-based schemes, test personnel need new tools to document, test, and troubleshoot these schemes. New tools include the following:

- New documentation
- Relay communications diagnostics
- Managed switches
- Network protocol analyzers
- GOOSE-enabled relay test sets

This paper describes and compares the use of these new tools with traditional testing techniques.

## I. OVERVIEW

Although conventional tools such as jumpers, voltmeters, continuity testers, and timers cannot test and troubleshoot IEC 61850 GOOSE (Generic Object-Oriented Substation Event) schemes, apply the following basic testing principles to identify new tools and techniques:

- Use complete and up-to-date documentation [1].
- Divide large schemes into smaller subsystems.
- Test overall performance of schemes using time-synchronized data.
- Create checklists or test plans [1].

Detailed documentation combined with thorough testing provides confidence and acceptance of new technologies, such as IEC 61850 GOOSE. Proper test tools and techniques minimize testing and troubleshooting time, reduce labor expenses, increase scheme availability, and increase overall system reliability.

Serial fiber-optic links are commonly used to pass discrete information between intelligent electronic devices (IEDs). Logical connections closely follow the physical connections in these connection-based methods. Some of the overall test methods applied to serial fiber-optic links can also be applied to GOOSE schemes, but the multicast nature of GOOSE and the flexibility of Ethernet require additional documentation and new tools.

## II. DOCUMENTATION

Documentation is the basis of all test plans. In a hard-wired breaker failure scheme, elementary diagrams and wiring diagrams document all of the contact I/O required to pass breaker failure initiate signals from the line and bus protective relays to the breaker failure relays. In a hard-wired scheme, a wiring diagram simultaneously documents both physical and logical connections among IEDs associated with the scheme.

In a system that uses GOOSE, the physical communications wiring diagrams do not adequately document the logical connections created by the publishing and subscribing of GOOSE messages. Each physical Ethernet connection can pass multiple messages in both directions simultaneously. The communications links shown in Fig. 1 can establish any or all of the following logical connections:

- Breaker failure initiate from the line protective relays (21A, 21C, and 21D) to the breaker failure relays (50BF1, 50BF2, and 50BF3).
- Breaker failure initiate from the bus differential relay (87B) to the breaker failure relays (50BF1, 50BF2, and 50BF3).
- Breaker failure tripping from each breaker failure relay to the other breaker failure relays.

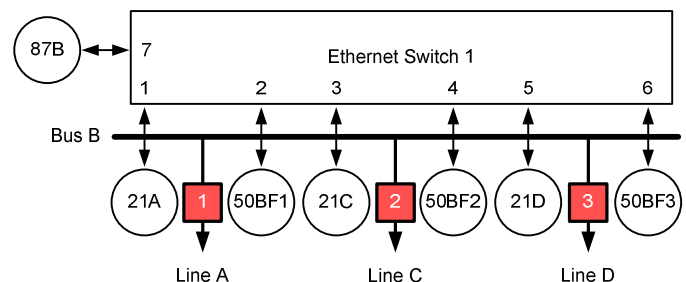

Fig. 1. Example physical communications diagram

When documenting these logical connections, protection and control scheme designers must perform the following:

- Identify all signals passed using GOOSE.
- Identify the publisher of each signal.
- Identify all subscribers of each signal.
- Provide a checklist to test each IED.
- Provide references to the physical connection diagram.

An example of using tables to document the logical connections is shown in Tables I and II. Organizing the list both by publishers and subscribers allows easy generation of checklists for commissioning testing, troubleshooting, and replacing failed equipment. Physical connection points in the table, including the switch and port numbers, aid in the review of managed Ethernet switch settings and association of logical connections with routes through the physical communications diagram. Specific data points of both publishing and subscribing IEDs link together logic diagrams between each pair of relays. Depending on the application, virtual local-area

network (VLAN) IEEE 802.1Q identifies and IEEE 802.1p priorities, multicast media access control (MAC) addresses, Internet Protocol (IP) addresses, standby backup connections, and subscriber GOOSE message quality data point assignments should also be included in the documentation.

The IEC 61850 standard defines a Substation Configuration Language (SCL) to configure and document systems [2]. Future software tools may automate the generation of drawings and checklists using SCL-based files to aid in testing.

TABLE I  
LOGICAL CONNECTIONS BY PUBLISHER

Message Name	Publisher					Subscriber				
	Device	Switch	Port	Data Point	Description	Device	Switch	Port	Data Point	Description
21A	21A	1	1	TRIP	Line A Trip	50BF1	1	2	CCIN004	Initiate BF 1
21C	21C	1	3	TRIP	Line C Trip	50BF2	1	4	CCIN004	Initiate BF 2
21D	21D	1	5	TRIP	Line D Trip	50BF3	1	6	CCIN004	Initiate BF 3
50BF1	50BF1	1	2	BFTRIP	Breaker 1 Failed	50BF2	1	4	CCIN001	Trip Breaker 2
50BF1	50BF1	1	2	BFTRIP	Breaker 1 Failed	50BF3	1	6	CCIN001	Trip Breaker 3
50BF2	50BF2	1	4	BFTRIP	Breaker 2 Failed	50BF1	1	2	CCIN002	Trip Breaker 1
50BF2	50BF2	1	4	BFTRIP	Breaker 2 Failed	50BF3	1	6	CCIN002	Trip Breaker 3
50BF3	50BF3	1	6	BFTRIP	Breaker 3 Failed	50BF1	1	2	CCIN003	Trip Breaker 1
50BF3	50BF3	1	6	BFTRIP	Breaker 3 Failed	50BF2	1	4	CCIN003	Trip Breaker 2
87B	87B	1	7	TRIP	Bus B Trip	50BF1	1	2	CCIN005	Initiate BF 1
87B	87B	1	7	TRIP	Bus B Trip	50BF2	1	4	CCIN005	Initiate BF 2
87B	87B	1	7	TRIP	Bus B Trip	50BF3	1	6	CCIN005	Initiate BF 3

TABLE II  
LOGICAL CONNECTIONS BY SUBSCRIBER

Message Name	Publisher					Subscriber				
	Device	Switch	Port	Data Point	Description	Device	Switch	Port	Data Point	Description
50BF2	50BF2	1	4	BFTRIP	Breaker 2 Failed	50BF1	1	2	CCIN002	Trip Breaker 1
50BF3	50BF3	1	6	BFTRIP	Breaker 3 Failed	50BF1	1	2	CCIN003	Trip Breaker 1
21A	21A	1	1	TRIP	Line A Trip	50BF1	1	2	CCIN004	Initiate BF 1
87B	87B	1	7	TRIP	Bus B Trip	50BF1	1	2	CCIN005	Initiate BF 1
50BF1	50BF1	1	2	BFTRIP	Breaker 1 Failed	50BF2	1	4	CCIN001	Trip Breaker 2
50BF3	50BF3	1	6	BFTRIP	Breaker 3 Failed	50BF2	1	4	CCIN003	Trip Breaker 2
21C	21C	1	3	TRIP	Line C Trip	50BF2	1	4	CCIN004	Initiate BF 2
87B	87B	1	7	TRIP	Bus B Trip	50BF2	1	4	CCIN005	Initiate BF 2
50BF1	50BF1	1	2	BFTRIP	Breaker 1 Failed	50BF3	1	6	CCIN001	Trip Breaker 3
50BF2	50BF2	1	4	BFTRIP	Breaker 2 Failed	50BF3	1	6	CCIN002	Trip Breaker 3
21D	21D	1	5	TRIP	Line D Trip	50BF3	1	6	CCIN004	Initiate BF 3
87B	87B	1	7	TRIP	Bus B Trip	50BF3	1	6	CCIN005	Initiate BF 3

### III. DIVIDE AND CONQUER

Larger systems may include three or more Ethernet switches and other equipment in the path between GOOSE message publishers and subscribers. Troubleshooting a logical path through these systems includes the review of the publishing IED logic settings, publishing IED communications settings, physical connections to each device, Ethernet switch settings, subscribing IED communications settings, and subscribing IED logic settings. In hard-wired schemes, test switches, indicator lights, device terminals, panel terminal blocks, control house patch racks, and outdoor marshalling cabinets are common points to test between output contacts and input coils. In GOOSE-based schemes, use IED GOOSE diagnostic reports, port mirroring in managed Ethernet switches, and communications analyzer software to divide the system and isolate problems starting from the publishing IED towards the subscribing IED.

In Fig. 2, the line IED publishes the status of its trip signal through three Ethernet switches to initiate the breaker failure logic in the breaker IED. When troubleshooting the breaker failure initiate signal shown in the example, analyze the SER (Sequential Events Recorder) and communications reports from the line IED first; then review data from Ethernet Switch 1. Follow the data through Ethernet Switches 2 and 3, and confirm function using the SER and communications reports from the breaker IED.

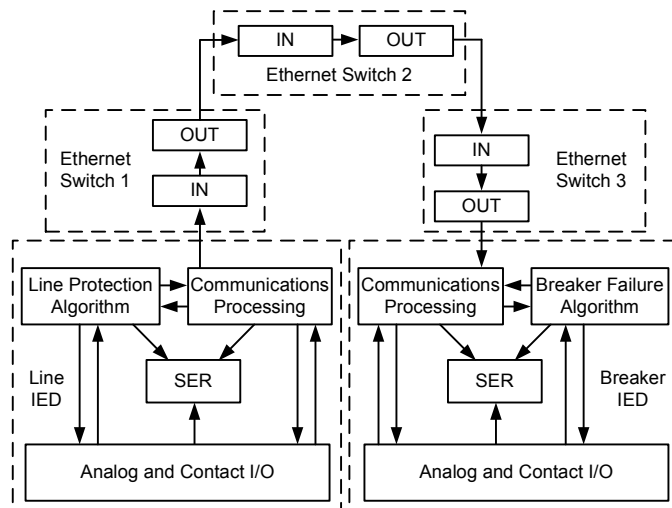

Fig. 2. Communications detail between publishing and subscribing IEDs in a large system

#### A. GOOSE-Enabled Relay Test Sets

Prior to connecting IEDs to a protection or automation scheme, they are tested individually in a test laboratory or panel factory. These tests check the calibration of the IED, ensure installation of proper protection and logic settings, and prove contact I/O operate as expected. Traditional relay test sets apply voltages and currents and then monitor contacts to test individual IEDs. In a GOOSE-based scheme, contact I/O are replaced with GOOSE messages on the network. As voltages and currents are applied to IEDs, network traffic must be monitored by a network protocol analyzer, a subscribing IED, or a GOOSE-enabled relay test set, as shown in Fig. 3.

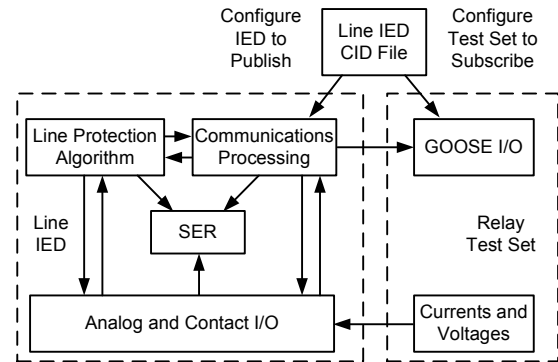

Fig. 3. Test set configured to subscribe to GOOSE messages

Although a network protocol analyzer or a subscribing IED can provide indication of a protection element operation, combining time-synchronized and time-stamped reports from multiple sources to document the test becomes lengthy and cumbersome. Without a time stamp or time synchronization between the test injection equipment and monitoring equipment, timing of protection algorithms cannot be measured.

The use of GOOSE-enabled relay test sets reduces time and effort required to document and report results. Simplify configuration with the ability to import the Configured IED Description (CID) files used to set the communications of the IEDs. Also, test documentation becomes consistent with hard-wired schemes because GOOSE I/O appear similar to contact I/O in test reports.

GOOSE-enabled test sets are superior to network analyzers and extra IEDs when testing requires both simulation and monitoring of GOOSE messages, as shown in Fig. 4. The test set must simulate an initiate signal from the line IED to the breaker IED and monitor the breaker failure trip signal distributed from the breaker IED. Multiple CIDs must be imported into the relay test set to configure it to simulate the line IED and to subscribe to messages from the breaker IED. Import additional CID files into the relay test set to simulate breaker failure signals distributed by other breaker failure relays on the bus or to simulate the trip signal from the bus differential relay.

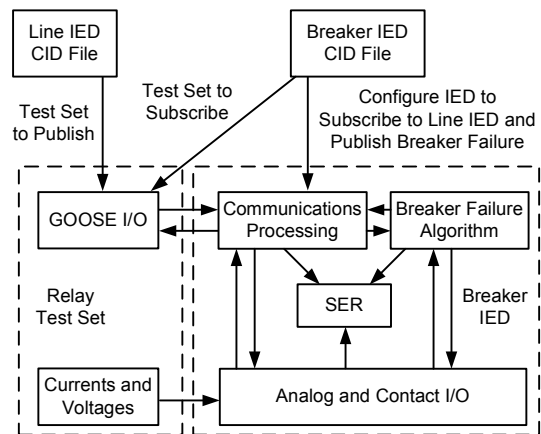

Fig. 4. Test set configured to simulate line IED and monitor breaker IED GOOSE messages

### B. IED GOOSE Diagnostic Reports

Many GOOSE-enabled IEDs are able to generate diagnostic reports summarizing key real-time statistics of the GOOSE messages received and transmitted. Because no special equipment or settings are required to use the IED GOOSE diagnostic reports, these reports are the most commonly used tool when testing or troubleshooting GOOSE schemes. The IED GOOSE diagnostic reports are sufficient to verify communications links across small, simple networks using a single unmanaged Ethernet switch. These reports provide a quick summary of the IED GOOSE messages transmitted/published to the network and the messages received/subscribed from the network. The example reports in Fig. 5 show entries from both publishing and subscribing IEDs, corresponding to a message used to transfer a trip signal from a line IED to initiate breaker failure logic in a breaker IED.

Line IED 21A						
GOOSE Transmit Status						
MultiCastAddr	Ptag:Vlan	StNum	SqNum	TTL	Code	
-----						
S21ACFG/LLN0\$GOS\$S21A						
01-0C-CD-01-00-01	4:2	2	140	1000		
Data Set: S21ACFG/LLN0\$DSet13						
GOOSE Receive Status						
MultiCastAddr	Ptag:Vlan	StNum	SqNum	TTL	Code	
-----						
No GOOSE Rx subscriptions available						

Breaker IED 50BF1						
GOOSE Transmit Status						
MultiCastAddr	Ptag:Vlan	StNum	SqNum	TTL	Code	
-----						
S50BF1CFG/LLN0\$GOS\$S50BF1						
01-0C-CD-01-00-02	4:1	2	594	852		
Data Set: S50BF1CFG/LLN0\$DSet13						
GOOSE Receive Status						
MultiCastAddr	Ptag:Vlan	StNum	SqNum	TTL	Code	
-----						
S87BCFG/LLN0\$GOS\$GooseDSet13						
01-0C-CD-01-00-04	:	0	0	0	TTL EXPIRED	
Data Set: S87BCFG/LLN0\$DSet13						
S50BF3CFG/LLN0\$GOS\$S50BF3						
01-0C-CD-01-00-07	4:1	1	242	1999		
Data Set: S50BF3CFG/LLN0\$DSet13						
S21ACFG/LLN0\$GOS\$S21A						
01-0C-CD-01-00-01	4:2	2	140	1554		
Data Set: S21ACFG/LLN0\$DSet13						
S50BF2CFG/LLN0\$GOS\$S50BF2						
01-0C-CD-01-00-0A	4:1	1	154	3027		
Data Set: S50BF2CFG/LLN0\$DSet13						

Fig. 5. GOOSE diagnostic reports from a pair of corresponding publishing and subscribing IEDs

The GOOSE diagnostic reports include the message label, multicast address, priority tag, VLAN identifier, and data set name. Real-time statistics for each message include the status number, sequence number, time-to-live (TTL), and error code [3]. Sequence numbers are incremented for every message that is published. State numbers are incremented for every state change in the data that are published. GOOSE diagnostic reports from publishing and subscribing IEDs with matching sequence and state numbers and continuously incrementing sequence numbers generally indicate that a healthy communications path is available between the IEDs. TTL and time-to-wait (TTW) correspond to the maximum time before the next message is sent or received [2]. Errors in the subscribing IED GOOSE diagnostic report, such as TTL expiration, coupled with healthy indications from the publishing IED GOOSE diagnostic report usually signify a physical connection problem or Ethernet switch settings problem.

Use the GOOSE diagnostic reports to quickly verify establishment of all documented logical connections. Because of the multicast nature of GOOSE, these reports only document IED subscription at the ends of the communications links and cannot be solely relied upon to ensure availability of all redundant communications paths. They also do not provide any latency information between publishing and subscribing IEDs.

### C. Port Mirroring

Advanced managed Ethernet switches buffer data, segregate networks, and prioritize data based on the IEEE 802.1Q and IEEE 802.1p standards. These standards allow efficient use of bandwidth and minimize latencies for time-critical GOOSE messages by restricting data to specific ports and reordering outgoing message packets [2]. VLAN identification (VLAN ID) settings make sure that IEDs receive only the messages that they should, based on the protection and control scheme design. Because of these functions, physically connecting equipment to the same Ethernet switch does not guarantee that messages pass between the equipment. Errors in Ethernet switch settings can prevent messages from passing to the next switch or the subscribing IED.

Fortunately, newer advanced Ethernet switches also provide the ability to inspect data entering and exiting each port using port mirroring, as shown in Fig. 6. This is similar to checking voltage at various terminal blocks and test switches between a contact and coil in a hard-wired scheme. Settings in an Ethernet switch allow ingress and/or egress data from a single port to be directly routed to a test port. A computer with a network protocol analyzer, GOOSE-enabled relay test set, or IED configured to subscribe to specific GOOSE messages can connect to the test port to verify messages are entering and leaving the switch on correct ports. Incorrect VLAN or prioritization settings in the switch can prevent or delay messages from being sent out of the required ports.

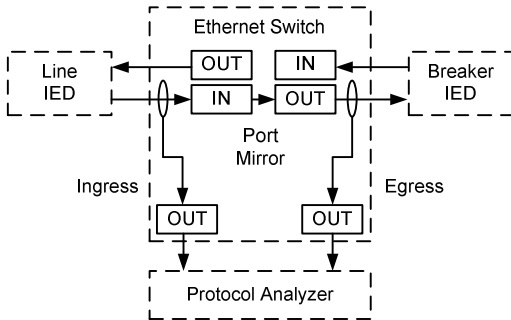

Fig. 6. Mirroring of ingress and egress data

#### IV. OVERALL SYSTEM TESTS

Overall scheme timing and redundancy are important to all GOOSE schemes used for protection, especially in transmission substations. Depending on system conditions, a few milliseconds of additional delay in a breaker failure scheme can result in power system instability [4]. Simple verification of communications links using IED GOOSE diagnostic reports does not measure latency across a network or between publishing and subscribing IEDs. Redundant communication further complicates measurement of latency by varying the latency based on the routing of the messages.

##### A. Latency Measurements

Use traditional test sets and timers to check latency between publishing and subscribing IEDs when the IEDs are physically located close together. When IEDs are physically far apart, limitations such as test lead length, possibility of ground potential rise, or lack of time-synchronized test sets prevent the measurement of delays between IEDs. Program time-synchronized SER data in publishing and subscribing IEDs to provide send and receive times of data passed using GOOSE messages, as shown in Fig. 7.

The difference in send and receive times in the SER reports represents the latency of message transit and processing between publishing and subscribing IEDs. IED time-stamped SER data can pass to substation real-time automation controllers for analysis, allowing continuous measurement, trending, and alarming of communications delays.

Line IED 21A				
#	DATE	TIME	ELEMENT	STATE
2	12/11/2009	11:13:50.491	TRIP	TRIP
1	12/11/2009	11:13:53.391	TRIP	Reset

Breaker IED 50BF1				
#	DATE	TIME	ELEMENT	STATE
8	12/11/2009	11:12:41.699	21A COMMS	FAIL
7	12/11/2009	11:12:52.717	21A COMMS	OK
6	12/11/2009	11:13:13.275	50BF2 COMMS	FAIL
5	12/11/2009	11:13:27.535	50BF2 COMMS	OK
4	12/11/2009	11:13:33.807	50BF3 COMMS	FAIL
3	12/11/2009	11:13:41.863	50BF3 COMMS	OK
2	12/11/2009	11:13:50.495	21A Trip	TRIP
1	12/11/2009	11:13:53.398	21A Trip	Reset

Fig. 7. SER reports from publishing and subscribing IEDs

The transmission time is the maximum time allowed for a data exchange through a communications system. IEC 61850-5 describes the transmission time as the time duration between the action of communicating a value from the logic processing of one device to the logic processing within a second device as part of an application. Fig. 8 illustrates time  $t_a$  as the time duration of the communications processing algorithm within the Physical Device 1 (IED 1). This algorithm uses data received from the input and logic processing of IED 1 as contents of messages that it creates and publishes. Detecting, processing, time-stamping, and creating an SER record of a physical contact input change of state in IED 1 are typical functions included in  $f_1$ . Time  $t_b$  represents the actual transit time of the message across the network between the IEDs. Time  $t_c$  is the time duration of the communications processing algorithm within Physical Device 2 (IED 2), which receives and processes the message from IED 1. The function  $f_2$  in IED 2 represents processing the message contents received from IED 1, subsequent closure of a physical output contact, associated time stamp, and SER record [2].

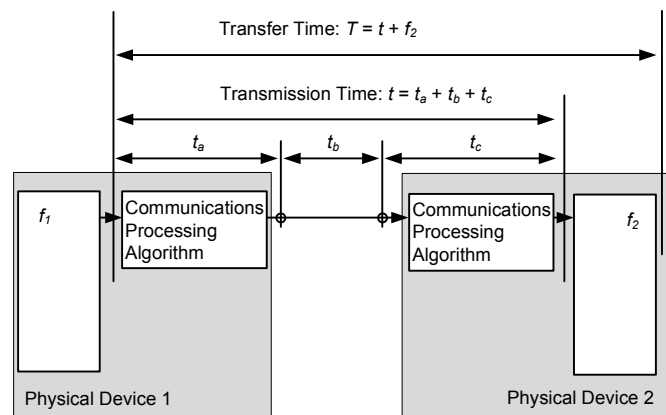

Fig. 8. SER time difference and transfer time, including time to detect, transfer, and process change

As shown in Fig. 8, the time duration to create and deliver messages between IEDs via a protocol is the message transmission time, represented by (1).

$$\text{Transmission Time} = t_a + t_b + t_c \quad (1)$$

The time duration to publish information in IED 1, deliver it via a protocol message, and act on it in IED 2 is the information transfer time, represented by (2).

$$\text{Transfer Time} = \text{Transmission Time} + f_2 \quad (2)$$

This information transfer time duration is the time truly useful to the design engineer because it represents actually performing an action as part of a communications-aided automation or protection scheme. Transfer time is easily measured as the time difference between the time-stamped SERs in IEDs with synchronized clocks. Message transit ( $t_b$ ) through the network, or message transit latency, is a subset of this difference. Existing Ethernet technology does not support measuring message transit latency.

When using IED time-stamped SER data, ensure the time-stamp accuracy is sufficient to measure the latencies. Many Ethernet-based time-set protocols, such as Distributed Network Protocol (DNP3), and low-resolution computer time-synchronization protocols, such as Network Time Protocol (NTP) and Simple Network Time Protocol (SNTP), lack sufficient accuracy to measure the latency of GOOSE-based schemes. High-accuracy IED clock time-synchronization and distribution techniques with accuracies of 1 millisecond or better, such as Global Positioning System time synchronization, IRIG-B synchronization, and IEEE 1588 Precision Time Protocol (PTP), must time-stamp data to measure latencies.

### B. Redundant Communication

Because of the criticality of the data passed using GOOSE, redundant communications paths are commonly used to increase availability of GOOSE-based schemes. The Rapid Spanning Tree Protocol (RSTP) in a switch manages multiple communications paths and reconfigures the system topology in case of a physical path failure, such as a cut cable, failed port, or loose connection [2]. IED SER data and GOOSE diagnostic reports do not verify that all possible redundant paths are available. IED data alone also do not ensure latency across longer paths. In a test laboratory environment and during commissioning, both long and short redundant communications paths should be sequentially broken to check functionality and to measure latencies using all intended redundant paths, as shown in Fig. 9.

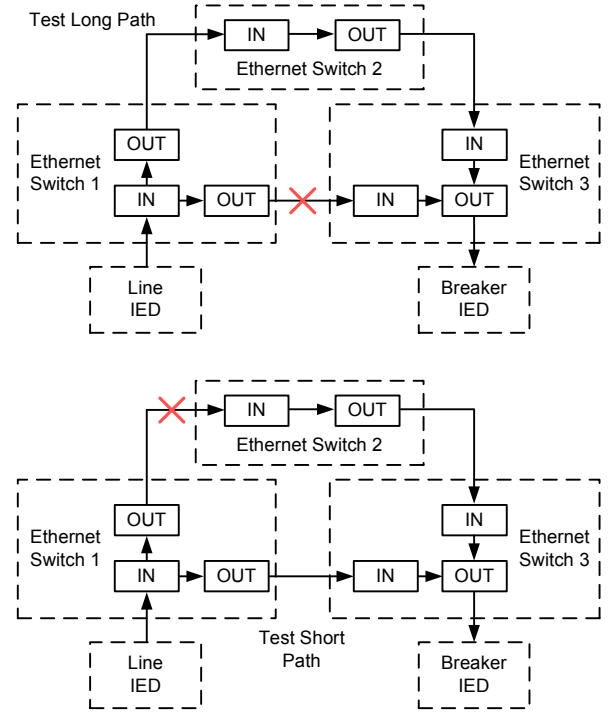

Fig. 9. Test redundant communications paths

## V. CONCLUSIONS

Traditional tools do not apply to GOOSE-based schemes. Applying primary testing and troubleshooting principles effectively identifies proper tools and techniques to test GOOSE-based schemes. Testing begins with proper documentation of all physical and logical communications links between publishing and subscribing IEDs to allow creation of checklists and test plans. Port mirroring, GOOSE-enabled test sets, network protocol analyzers, and IED GOOSE diagnostic reports allow division of schemes into pieces that can be tested and monitored. Measure overall system delays using time-stamped, time-synchronized data from subscribing and publishing IEDs. Delays must be measured for different redundant communications paths. Using these tools and techniques demystifies GOOSE-based schemes and provides confidence to test personnel.

## VI. REFERENCES

- [1] K. Zimmerman and D. Costello, "Lessons Learned From Commissioning Protective Relaying Systems," proceedings of the 62nd Annual Conference for Protective Relay Engineers, College Station, TX, March 2009.
- [2] D. Hou and D. Dolezilek, "IEC 61850 – What It Can and Cannot Offer to Traditional Protection Schemes," proceedings of the 35th Annual Western Protective Relay Conference, Spokane, WA, October 2008.
- [3] H. Fischer, J. Gilbert, G. Morton, M. Boughman, and D. Dolezilek, "Case Study: Revised Engineering and Testing Practices Resulting From Migration to IEC 61850," proceedings of the 18th Annual DistribuTECH Conference and Exhibition, Tampa, FL, January 2008.
- [4] E. Atienza and R. Moxley, "Improving Breaker Failure Clearing Times," proceedings of the 36th Annual Western Protective Relay Conference, Spokane, WA, October 2009.

## VII. BIOGRAPHY

**Edsel Atienza** received his BSEE from the University of Idaho in 2001. He joined Schweitzer Engineering Laboratories, Inc. (SEL) in 2002 as an international field application engineer. In 2006, he joined Tampa Electric as a substation operations engineer responsible for relay testing and maintenance. He returned to SEL in 2008, serving the southeastern United States as a field application engineer.