

Ancillary functions

- Metering functions:
 - Phase voltages (Va, Vb, Vc), Phase-to-phase voltage (Vab, Vbc, Vca)
 - Symmetrical component voltages (V1, V2, V0)
 - Frequency (f), Max. and min. frequency (fmax, fmin)
 - Frequency rate of change (df/dt)
- Event Recording
 - Up to 200 most recent events time-tagged to 1ms resolution.
- Fault recording
 - Up to 4 most recent faults with phase-by-phase reports prior to and during fault conditions.
- Disturbance recording
 - 8 analog and 32 binary signal records.
 - Max. 5 records each of five seconds duration.
- Communication
 - RS485: Modbus, DNP3 or IEC 60870-5-103
 - Ethernet (100Base-TX or 100Base-FX): Modbus, DNP3 or IEC 61850 for model 412 only

Dimensions and Weight

- 4U (177mm) height,
- 1/3 x 19" (149mm) width (for model 410 and 411),
- 1/2 x 19" (223mm) width (for model 412)
- 151mm depth
- 1.5kg (for model 410 and 411)
- 1.8kg (for model 412)

Ordering code GRE130 - [] A - [] - []

Type :	
Voltage protection	GRE130
Model :	
Four pole	
2xBIs, 4xBOs + Fail	410
6xBIs, 4xBOs + Fail	411
6xBIs, 8xBOs + Fail	412
Rating :	
VT: 110V, f: 50/60Hz, 110/250Vdc/110/240Vac	1
CT: 1/5A, f: 50/60Hz, 48/110Vdc	2
VT: 110V, f: 50/60Hz, 24/48Vdc	A
Standard and language :	
IEC (English)	0
ANSI (English)	1
Communication :	
RS485 x 1 (Modbus/IEC 60870-5-103)	10
RS485 x 1 (Modbus/DNP3)	11
For others, see (*)	

(*) : The following options can be equipped when you select model 412.
 A0 : 100BASE-TX (Modbus/IEC 61850) x 1 port and RS485 (Modbus/IEC 60870-5-103) x 1 port
 A1 : 100BASE-TX (Modbus/IEC 61850/DNP3) x 1 port and RS485 (Modbus/DNP3) x 1 port
 C0 : 100BASE-FX (Modbus/IEC 61850) x 1 port and RS485 (Modbus/IEC 60870-5-103) x 1 port
 C1 : 100BASE-FX (Modbus/IEC 61850/DNP3) x 1 port and RS485 (Modbus/DNP3) x 1 port

TOSHIBA

TOSHIBA CORPORATION

Social Infrastructure Systems Company

72-34, Horikawa-cho, Saiwai-ku Kawasaki-shi, Kanagawa 212-8585, Japan
 Tel +81-44-331-1462 Fax +81-44-548-9540
<http://www.toshiba-relays.com>

- The information provided in this catalog is subject to change without notice.
- The information provided in this catalog is accurate as of 31 July 2014.
- The information provided in this catalog is presented only as a guide for the application of TOSHIBA products. No responsibility is assumed by TOSHIBA for any infringements of patents or other rights of third parties which may result from its use. No license is granted by implication or otherwise under any patent or patent rights of TOSHIBA or others.
- TOSHIBA products should not be embedded within downstream products production and sale of which are prohibited, under any law and regulation.
- Toshiba does not take any responsibility for incidental damage (including loss of business profit, business interruption, loss of business information and other pecuniary damage) arising out of the use or misuse of TOSHIBA products.

©Copyright 2014 Toshiba. All rights reserved.

TOSHIBA

Leading Innovation >>>

GRE130

Protection and Control for MV Systems



GRE-Series – GRE130

Multi-Function Voltage Protection and Control



GRE130 is a fully numerical multi-function voltage protection device designed for various applications in MV networks, drawing upon proven technologies developed over more than 100 years, and providing a comprehensive range of protection and control functions. This compact and cost-effective device can be applied not only as a feeder protection but also as a load shedding function providing under-frequency and rate of change of frequency relays together with back-up protections for HV feeders, transformers and machines.

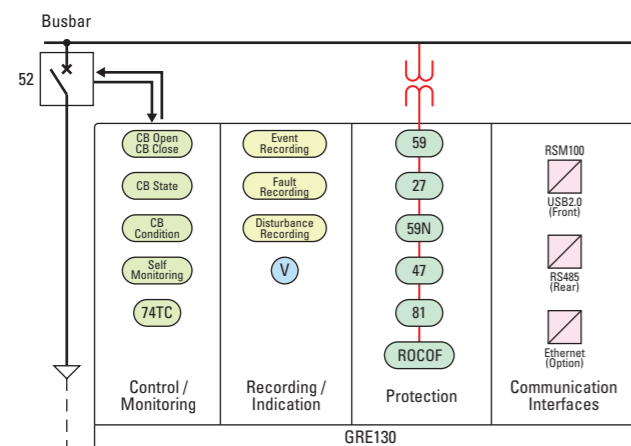

Features

- Voltage and frequency protection
- Applicable to 1-phase input (single phase-to-phase voltage and single phase-to-neutral voltage), 2-phase input (two phase-to-phase voltage and two phase-to-phase voltage with zero phase voltage) and 3-phase input (three phase-to-phase voltage, three phase-to-neutral voltage and three phase-to-neutral voltage with zero phase voltage)
- Feeder manager device with CB control function, 43R/L switch and comprehensive support functions
- Compact and cost-effective design
- Elementary, environmentally-friendly, easy to use and featuring enhanced product concepts

Model Number (ANSI)	GRE130 (-410/411)		
	1-ph	2-ph	3-ph
Protection			
Phase O/V (59)	✓	✓	✓
ZPS OV (59N)	✓		✓
Phase U/V (27)	✓	✓	✓
NPS O/V (47)		✓	✓
Frequency (81U/O)	(✓)	✓	✓
Frequency rate of change (df/dt)	(✓)	✓	✓
Control			
Local/Remote Control	✓	✓	✓
Monitoring			
Trip circuit supervision (74TC)	✓	✓	✓
Self supervision	✓	✓	✓
CB State Monitoring	✓	✓	✓

Model Number (ANSI)	GRE130 (-410/411)		
	1-ph	2-ph	3-ph
Monitoring			
Trip Counter Alarm	✓	✓	✓
CB Operate Time Alarm	✓	✓	✓
Communication			
USB port	✓	✓	✓
Remote Communication (Modbus, DNP3, IEC 60870-5-103 and IEC 61850)	✓	✓	✓
Others			
Two setting groups	✓	✓	✓
Menu-based HMI (16 x 8 char)	✓	✓	✓
Configurable LED (8 fixed and 6 configurable)	✓	✓	✓
Programmable Logic Controller (PLC)	✓	✓	✓